



Field Installed Options Vector 8100, 8500, 8600

Table of Contents

Battery Anti-Theft Bracket	1
Disconnect Batteries Warning Decal	2
Bottom Panel	3
Stand-alone, Non-standby Micro Bumper – Vector 8500 units only	4
Lower Bumper Installation Kit with Standby Bracket – Vector 8500 units only	6
Unit Bumper Installation Kit – Vector 8500 units only	8
Drain Line Extension	10
Fuel Line Fitting	11
Fuel Pump – Vector 8500 units only	13
LED Light Bar	15
Remote Monitor Sensor Kit, 75-Foot	17
Remote Monitor Sensor Kit, 100-Foot	19
Remote Monitor, Pulp Probe Kit – Vector 8500 and 8600 units only	21
Remote Monitor, Door Switch Kit	22
Low Fuel Sensor – 22” Diameter Tank – Vector 8500 and 8600 units only	24
Low Fuel Sensor – 36.5” Diameter Tank – Vector 8500 and 8600 units only	26

NOTE: For assistance, contact the Performance parts Group Customer Response Center Monday through Friday 8 a.m. to 6 p.m. EST at 1-800-255-7382. To contact the Performance Parts Group through the service mailbox, please email ppg.customerservice@carrier.utc.com.

North America
Carrier Transicold
700 Olympic Drive
Athens, GA 30601 USA
Tel: 1-706-357-7223
Fax: 1-706-355-5435

**Central America
and Mexico**
Ejercito Nacional No. 418
Piso 9, Torre Yumal
Col. Chapultepec Morales
11570 Mexico, D.F.
Tel: (5255) 9126.0300
Fax: (5255) 9126.0373



**United
Technologies**

Climate | Controls | Security
Carrier Transicold
Truck/Trailer Products Group
P.O. Box 4805
Syracuse, N.Y. 13221 U.S.A

www.carrier.transicold.com



A member of the United Technologies Corporation family. Stock symbol UTX
©2013 UTC Climate | Controls | Security Printed in U. S. A.

62-11717

Battery Anti-Theft Bracket

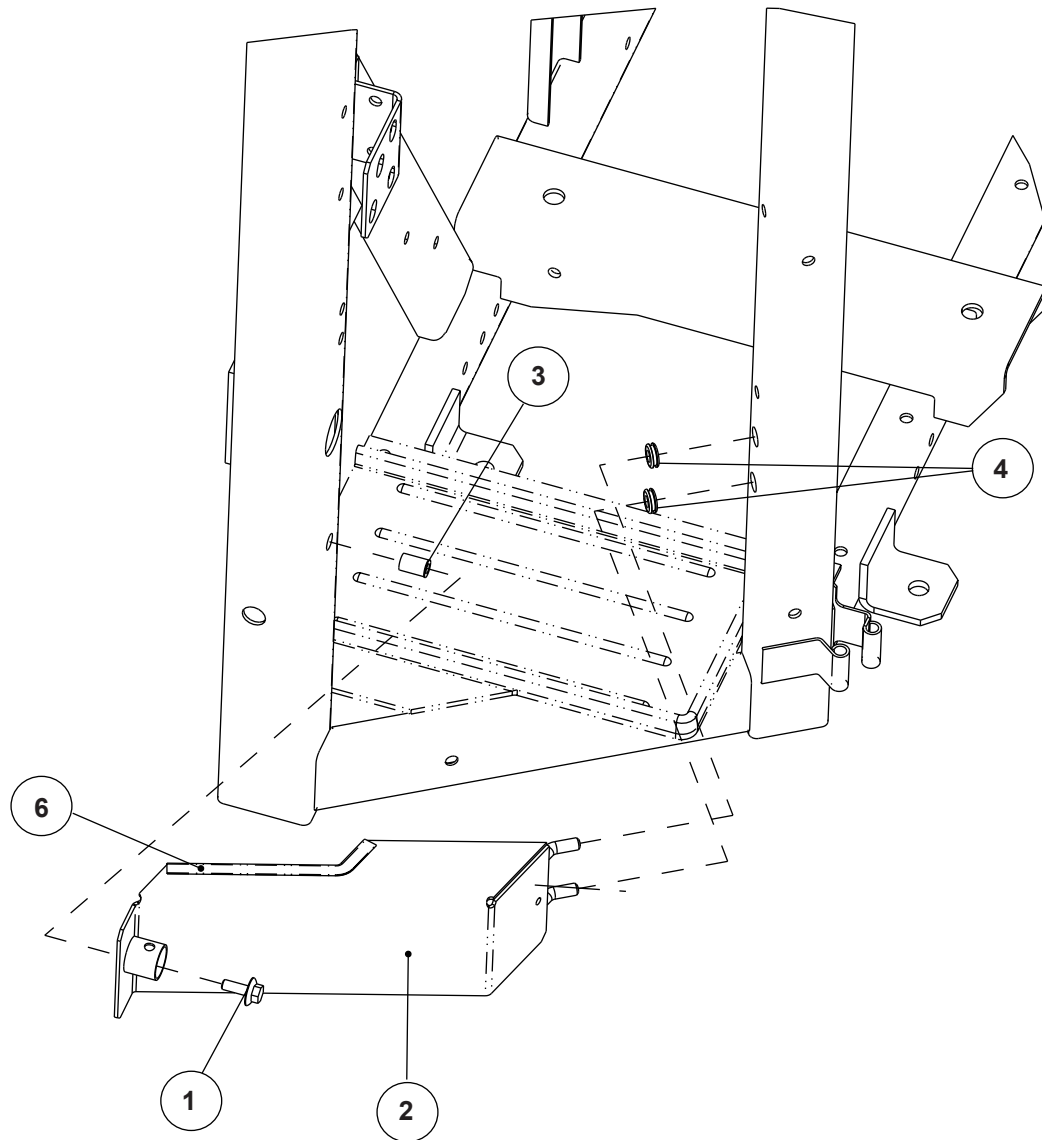

Item Number	Part Number	Part Description	Quantity
		Battery Anti-Theft Bracket - Includes:	
1	34-00919-08	Screw, Hex Washer Head, 5/16-18 x 1.0	1
2	86-03061-00	Bracket Assembly, Battery, Anti-Theft	1
3	34-06051-10	Rivnut, 5/16 - 18	1
4	58-00065-76	Grommet, 0.38 x 0.75	2
5	42-00183-22	Trim, Flexible, Fine, Pebble Black	0.56

Decal, Warning, Disconnect Batteries

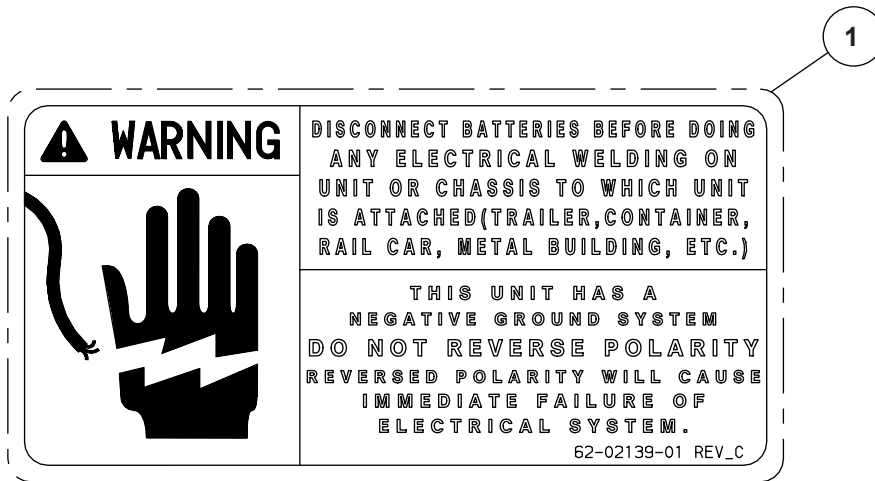

Item Number	Part Number	Part Description	Quantity
1	62-02139-01	Decal, Warning, Disconnect Batteries	4

Bottom Panel Kit

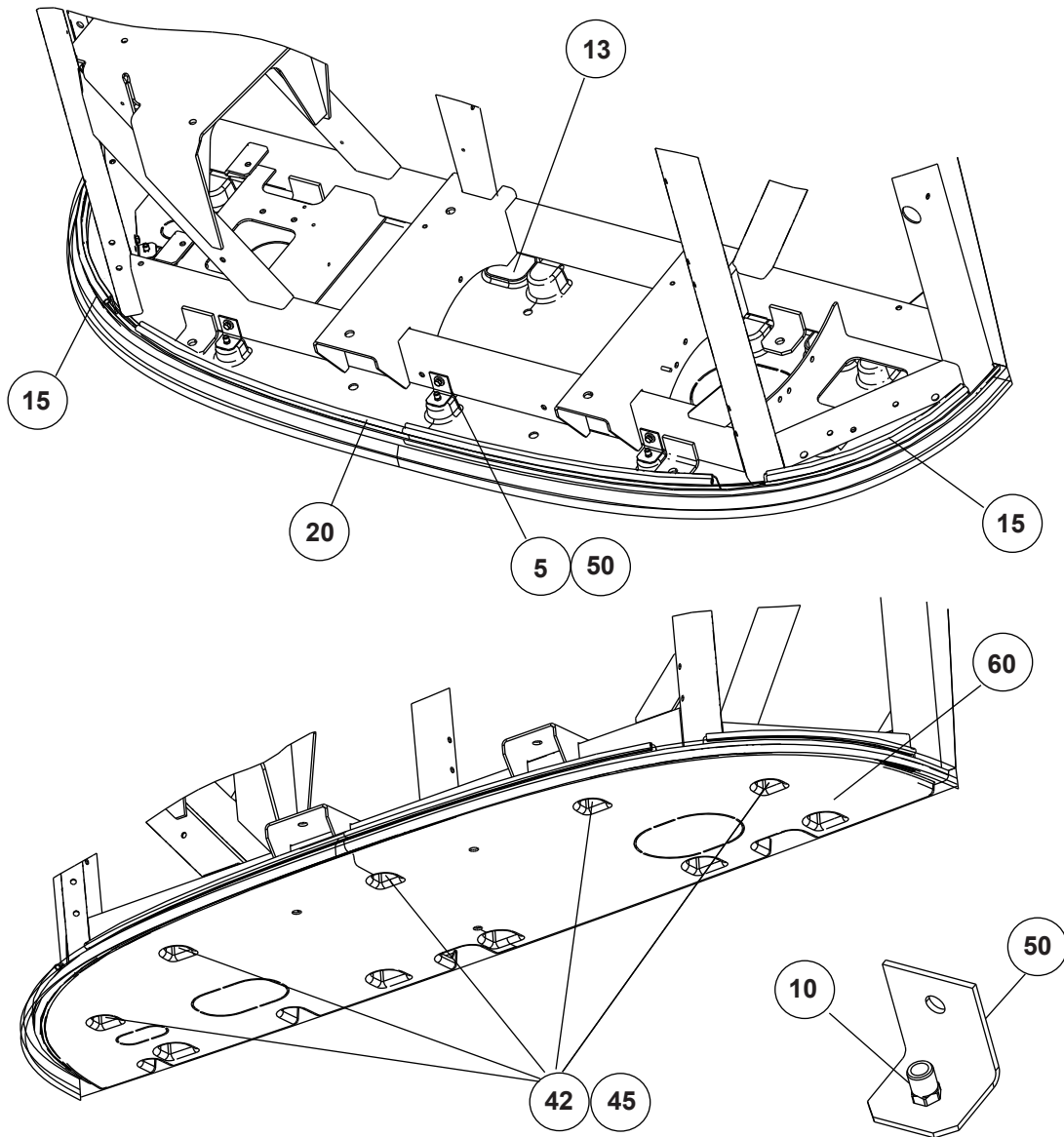

View from Bottom of Unit

Item Number	Part Number	Part Description	Quantity
		Bottom Panel - Includes:	
5	34-06331-20	Screw, Captive Washer, M6 x 20mm	3
10	34-01314-24	Rivnut, M6 x 1.0, Hex	3
13	42-00183-21	Trim, Flexible, Fine Pebble Black	0.625
15	42-00264-14	Seal, Trim, Black	2
20	42-00264-13	Seal, Trim, Black	1
42	34-06089-00	Washer, Fender, 1/4 Black, Nickel Plated	5
45	34-06331-25	Screw, Captive Washer, M6 x 25mm	5
50	68-08241-00	Angle, Mounting	3
60	58-04827-01	Panel, Bottom	1

Stand-Alone, Non-Standby Micro Bumper - Vector 8500 units only

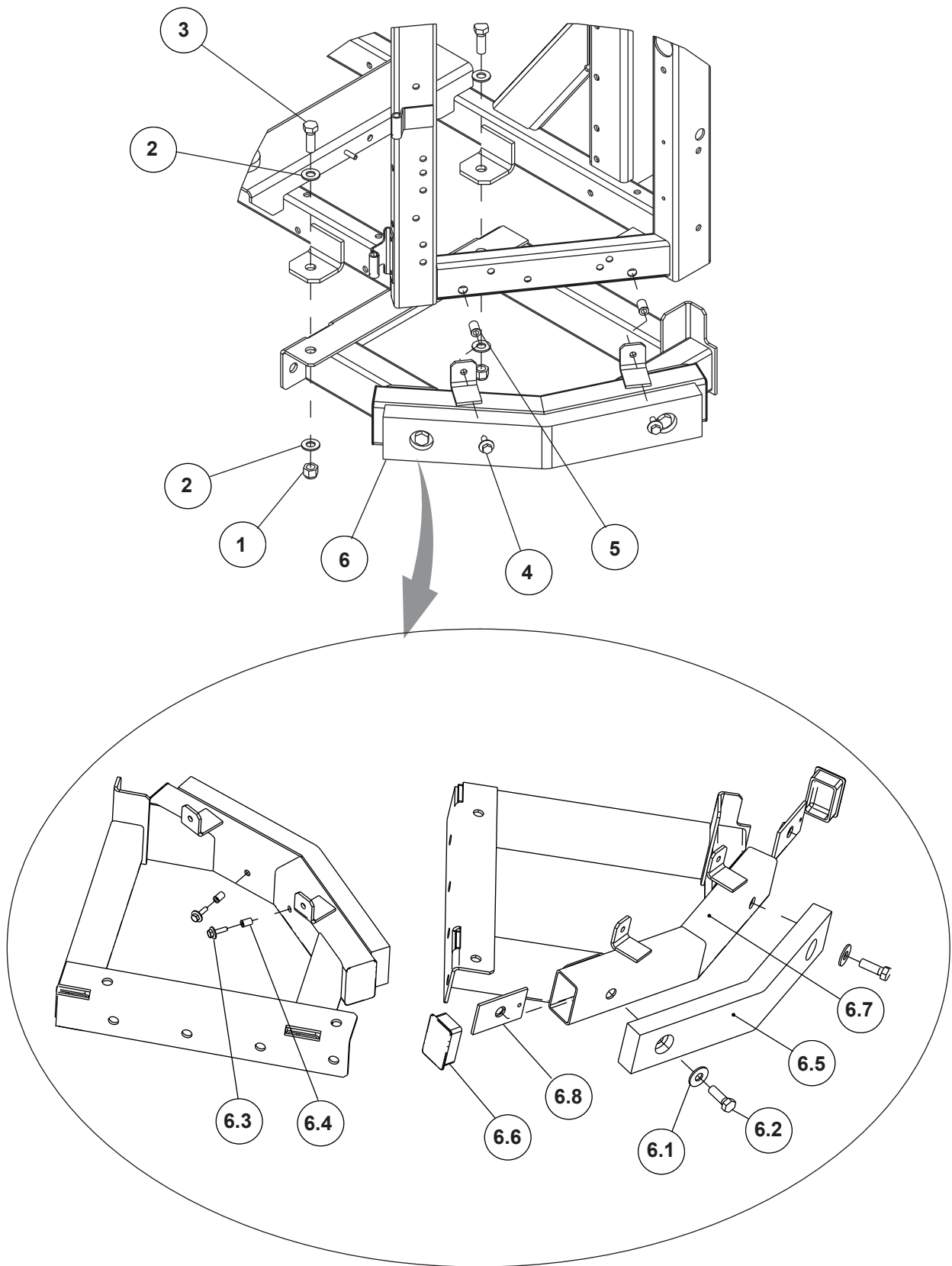

Item Number	Part Number	Part Description	Quantity
		Stand-Alone Micro Bumper - Includes	
1	34-00361-15	Nut, Self Lock, 1/2 - 13	2
2	34-00588-15	Washer, Plain, 1/2 SAE, 0.095 Thick	4
3	34-00678-12	Screw, Cap, Hex Head, 1/2 - 13 x 1.50	2
4	34-00919-08	Screw, Hex Washer Head, 5/16 - 18 x 1.00	2
5	34-06051-10	Rivnut, 5/16 - 18	2
6	79-02343-00	Bumper Assembly, Micro - Includes:	1
6.1	34-00366-15	Washer, Plain, 1/2	2
6.2	34-00678-12	Screw, Cap, Hex Head, 1/2 - 13 x 1.50	2
6.3	34-01294-08	Screw, Captive Washer, 1/4 - 20 x 1.00	2
6.4	34-06051-06	Rivnut, 1/4 - 20	2
6.5	58-01372-01	Bumper, Rubber, 1.25 x 3.00	1
6.6	58-04099-04	Plug, Rubber, 1.737 x 2.737, Rectangular	2
6.7	86-03054-00	Frame Assembly, Micro Bumper	1
6.8	86-03055-00	Plate Assembly, Nut, Micro Bumper	2

Lower Bumper Installation Kit with Standby Bracket - Vector 8500 units only

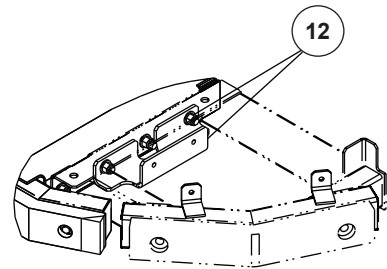
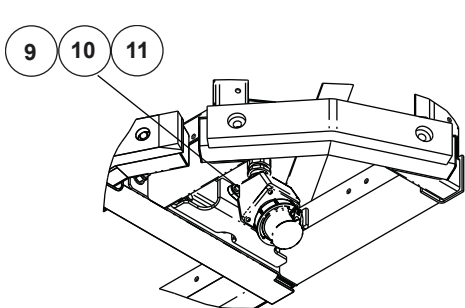
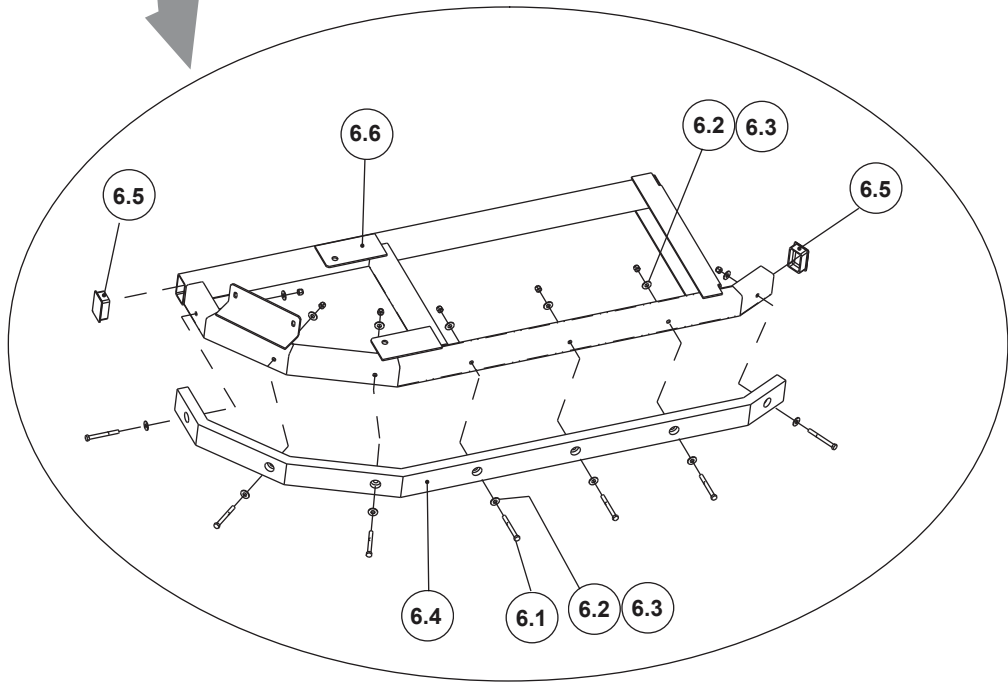
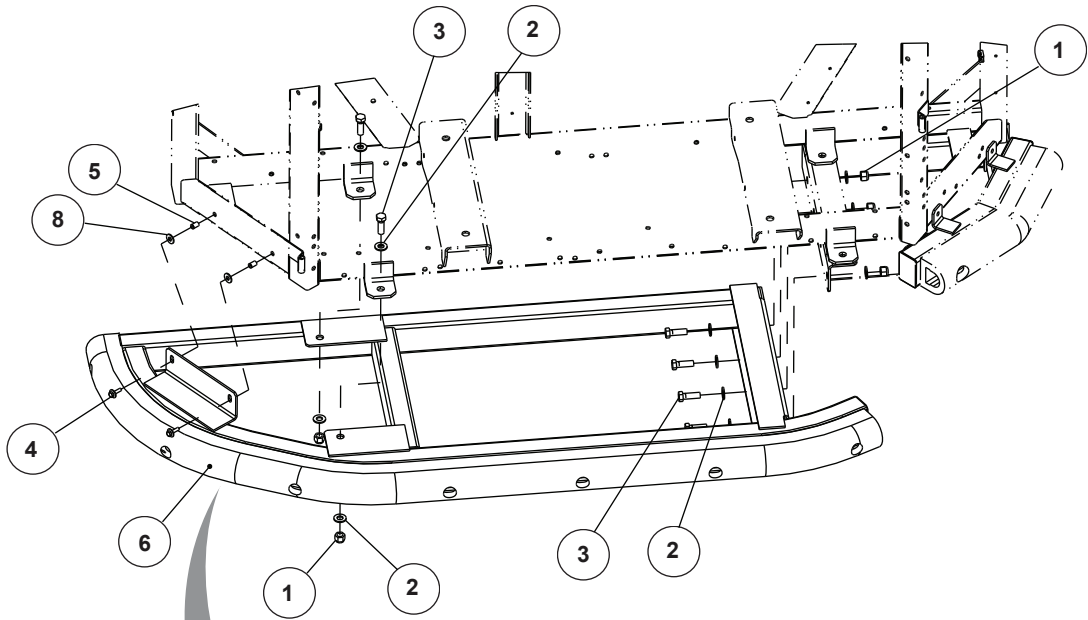

Item Number	Part Number	Part Description	Quantity
		Lower Bumper - Includes:	1
1	34-00361-15	Nut, Self-Locking, 1/2-13	6
2	34-00588-15	Washer, Plain, 1/2 SAE, 0.095 Thick	12
3	34-00678-12	Screw, Cap, Hex Head, 1/2-13 x 1.50	6
4	34-00918-08	Screw, Hex Washer Head, 1/4-20 x 1.00	2
5	34-06051-06	Rivnut, 1/4-20	2
6	79-02349-00	Bumper Assembly, Lower - Includes:	1
6.1	34-00304-28	Screw, Cap, HXHD, 3/8-16 x 3.50	7
6.2	34-00366-13	Washer, Plain, 3/8	7
6.3	34-00368-13	Washer, Lock, 3/8-16	7
6.4	34-00361-13	Nut, Self-Locking, 3/8-16	7
6.5	58-01372-02	Bumper, Rubber, 1.25 x 3.00	1
6.6	58-04099-04	Plug, Rubber, 1.737 x 2.737	1
6.7	86-03083-00	Frame Assembly, Bumper	1
8	34-00366-12	Washer, Plain, 5/16	2

Unit Bumper Installation Kit - Vector 8500 units only

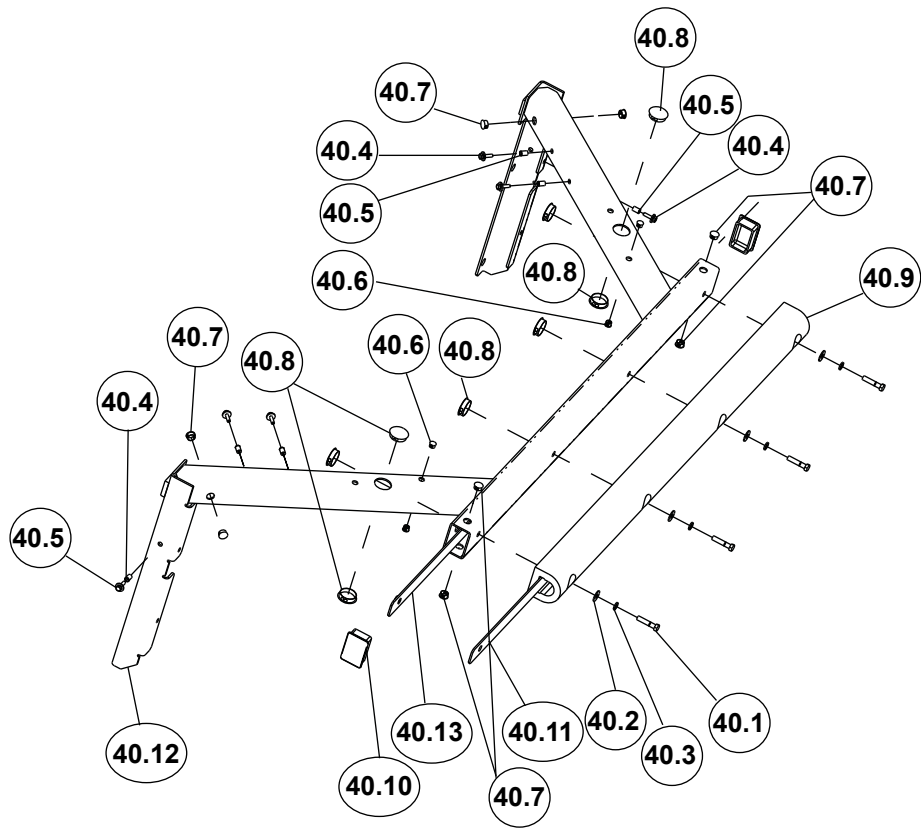
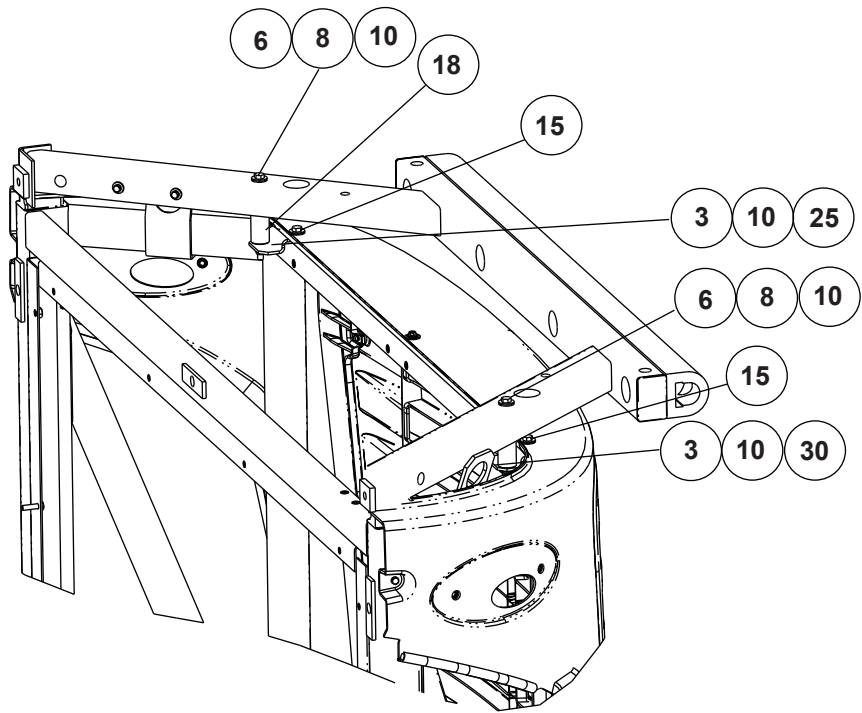

40 Unit Bumper Assembly

Item Number	Part Number	Part Description	Quantity
		Whit Bumper, Includes:	
3	34-00304-10	Screw, Cap, Hex Head, 3/8 - 16 x 1.25	2
6	34-00304-44	Screw, Cap, Hex Head, 3/8 - 16 x 5.50	2
8	34-00361-13	Nut, Self-Locking, 3/8 - 16	2
10	34-00366-13	Washer, Plain, 3/8	10
15	34-06051-14	Rivnut, 3/8 - 16	2
18	48-00419-00	Spacer	2
25	68-16134-00	Spacer	1
30	68-16135-00	Spacer	1
40	79-01950-00	Bumper Assembly, Unit Bumper, Includes:	1
40.1	34-00304-14	Screw, Cap, Hex Head, 3/8-16 x 1.75 Long	4
40.2	34-00366-13	Washer, Plain	4
40.3	34-00368-13	Washer, Lock, 3/8 Spring	4
40.4	34-01294-08	Screw, Captive Washer, 1/4-20 x 1.00 Long	7
40.5	34-06051-06	Rivnut, 1/4	7
40.6	58-00616-02	Plug, Hole, 0.50 Diameter	4
40.7	58-00616-01	Plug, Hole, 0.69 Diameter	8
40.8	58-00616-16	Plug, Hole, 1.50 Diameter	8
40.9	58-01330-00	Bumper, Rubber, Extruded	1
40.10	58-04099-04	Plug, Rubber, 1.737 x 2.737 Rectangular	2
40.11	68-07609-00	Plate	1
40.12	86-04673-00	Frame Assembly, Unit Bumpers	1
40.13	86-02992-00	Plate Assembly, Nut	1

Drain Line Extension Installation Kit - Vector 8500 and 8600 units only

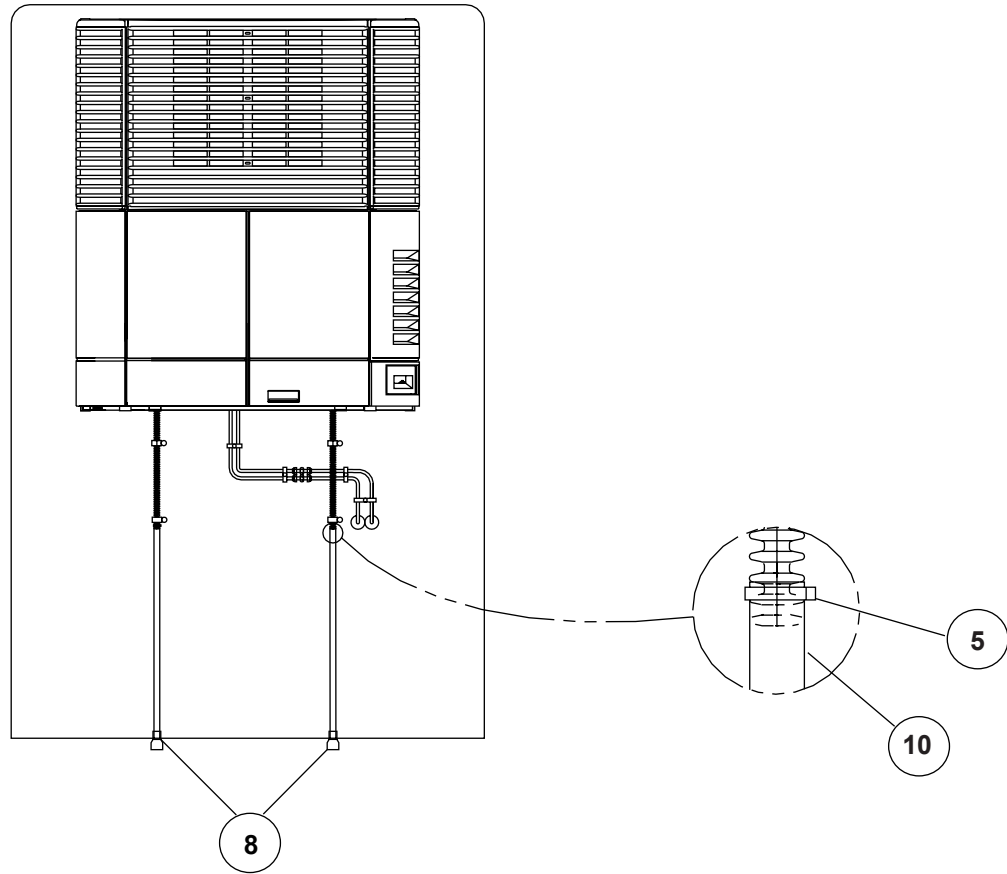

Item Number	Part Number	Part Description	Quantity
		Drain Line Extension - Includes:	
5	58-00712-15	Clamp, Hose, 0.985 - 1.135, Snap	2
8	58-00253-00	Kazoo, Drain Hose Fitting	2
10	58-00772-07	Hose, Drain, Molded	2

Fuel Fitting Line - Vector 8500 and 8600 units only

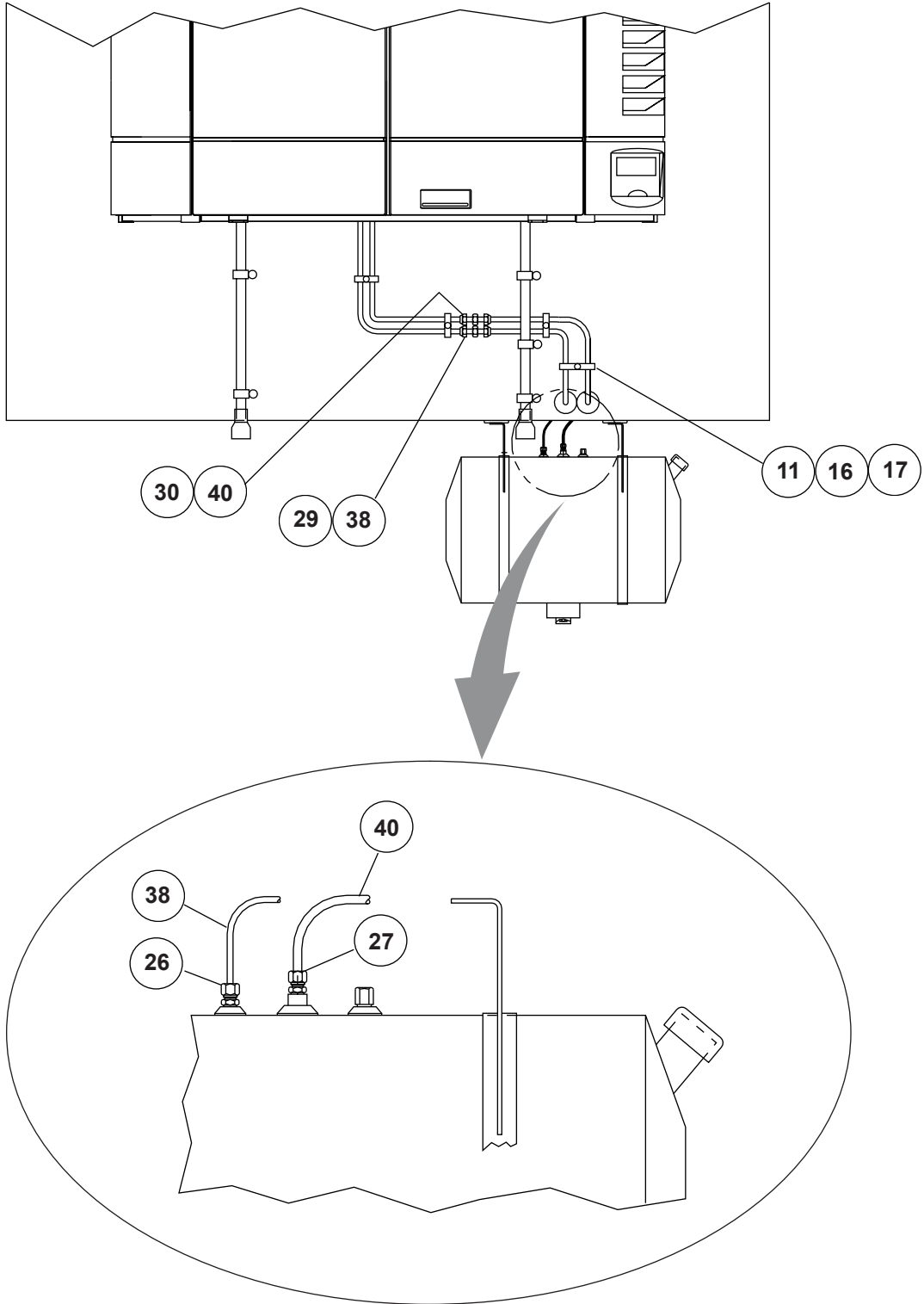

Item Number	Part Number	Part Description	Quantity
		Installation Kit, Fuel Line, Fitting - Includes:	
11	34-01276-08	Screw, Hex, Washer Head, 1/4 x 1.00, Self-Tapping	6
16	34-00373-01	Clamp, Tube, 0.25 Diameter, Cushioned	6
17	34-00373-03	Clamp, Tube, 0.38 Diameter, Cushioned	6
26	40-00450-00	Connector, Male, 1/4 Tube x 1/4 MPT	1
27	40-00450-01	Connector, Male, 3/8 Tube x 1/4 MPT	1
29	40-00349-00	Union, 1/4 Tube	1
30	40-00349-01	Union, 3/8 Tube	1
38	58-01390-00	Tube, Fuel, 1/4 OD	35
40	58-01391-00	Tube, Fuel, 0.375 OD	35

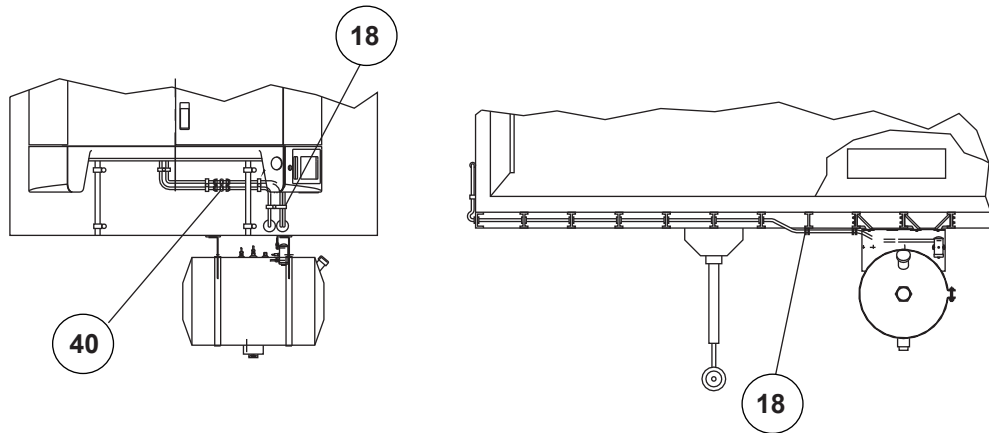

Typical Tank Arrangement

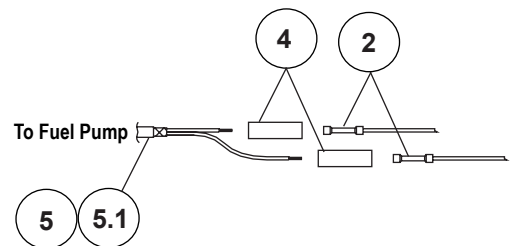
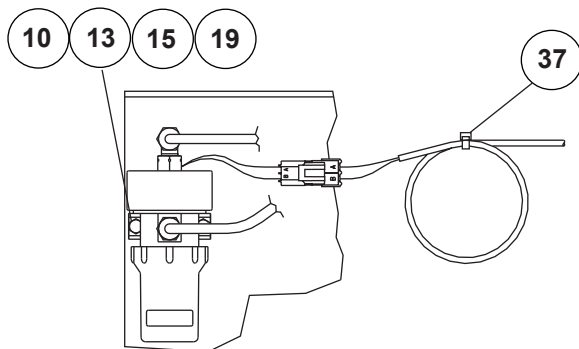
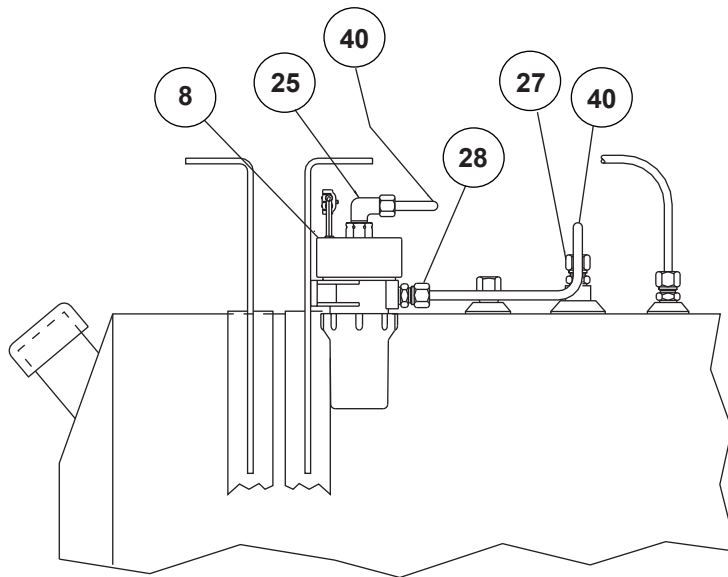

Item Number	Part Number	Part Description	Quantity
		Fuel Pump Kit - Includes	
2	22-00066-02	Connector, Butt Splice, 14-16 GA	2
4	22-01327-02	Tube, Heat Shrink, 1/4-20 x 2.00 Long	2
5	22-60287-01	Harness, Fuel Pump - Includes:	1
5.1	22-01585-00SV	Connector, 2-Wire (Mates with 22-02392-00SV)	1
8	30-01108-03SV	Pump, Fuel, Electric with Connector - Includes	1
8.1	30-01108-23	Bowl, Fuel Pump	1
8.2	30-01108-22	Gasket, Bowl	1
8.3	30-01108-20	Filter, Fuel Pump	1
8.4	22-02392-00SV	Connector, 2-Wire (Mates with 22-01585-00SV)	1
10	34-00300-08	Screw, Cap, HXHD, 1/4-20 x 1.00	2
13	34-00361-11	Nut, Self-Locking, 1/4-20	2
15	34-00372-11	Washer, Lock, 1/4 External Tooth	2
18	44-00102-01	Clamp, Cushioned, .50 Diameter	3
19	34-00588-11	Washer, Plain, 1/4 SAE, .065 Thick	4
25	40-00342-02	Elbow, Mail, 3/8 Tube x 1/8 NPTE	1
27	40-00450-01	Connector, Male, 3/8 Tube x 1/8 MPT	1
28	40-00343-07	Connector, Male, 3/8 Tube x 1/8 NPTE	1
37	58-00079-02	Sta-Strap, 0-1.75 Diameter Cable	4
40	58-01391-00	Tube, Fuel, .375 OD	18

LED Light Bar

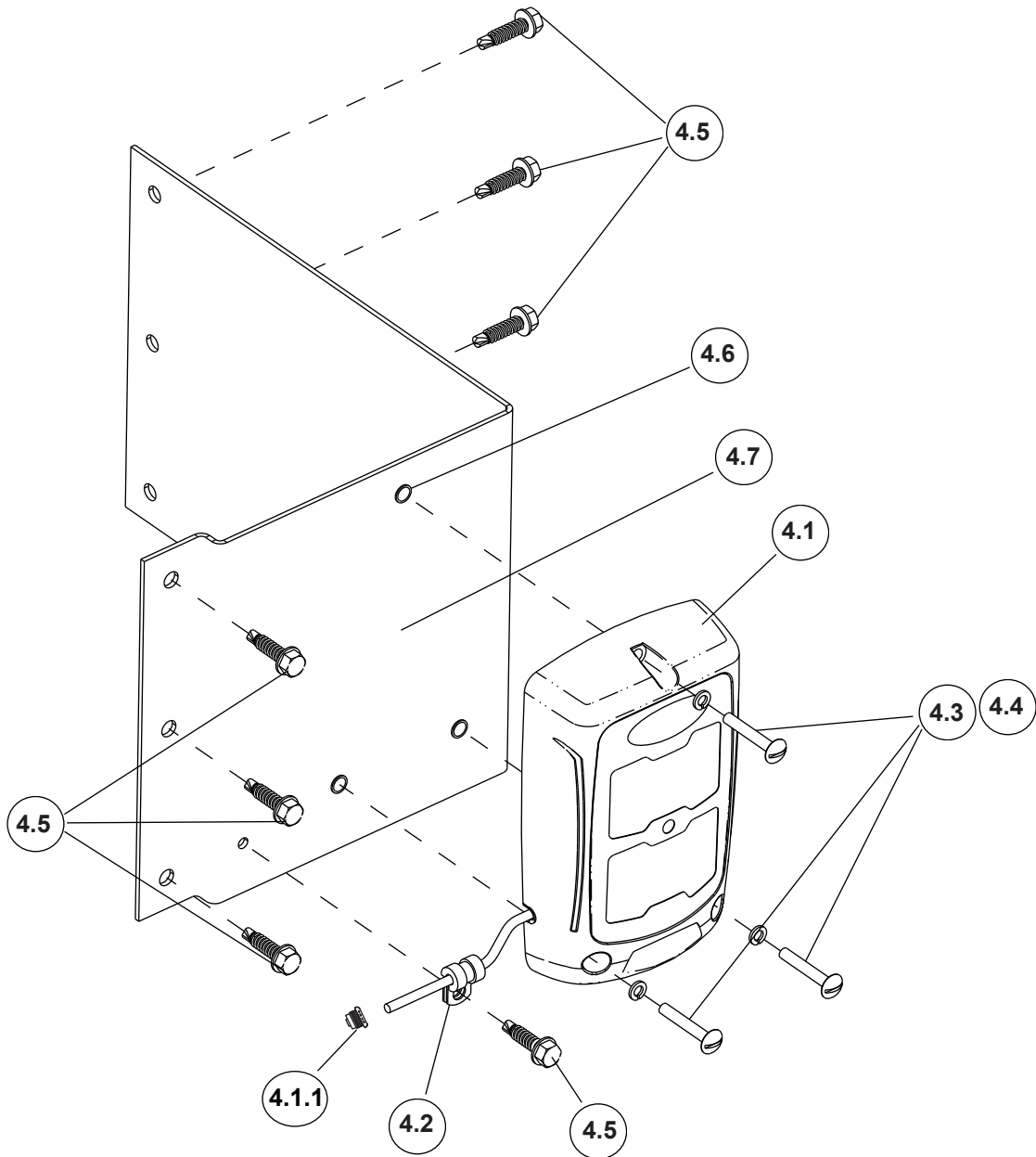

4.8 Sta-Strap, Cable Clamp, - 0 - 1075 Diameter (not on drawing)

5 Fuse, 5A (not shown)

Item Number	Part Number	Part Description	Quantity
		LED Light Bar - Includes	
4	76-02000-00	LED Light Bar Installation Kit - Includes:	
4.1	22-02842-00	Light Bar Assembly, LED - Includes:	1
4.1.1	22-50078-04SV	Connector, Male, 8-Pin	1
4.2	34-00373-50	Clamp, Tube, 0.19 Diameter, Cushioned	5
4.3	34-00670-20	Screw, Round Head, 10 - 32 x 1.25	3
4.4	34-00663-09	Washer, Lock, 10 Spring	3
4.5	34-01276-08	Screw, Hex Washer Head, 1/4 x 1.00, Self-Tapping	11
4.6	34-06051-34	Rivnut, 10 - 32	3
4.7	68-08042-00	Bracket, Mounting	1
4.8	58-00079-02	Sta-Strap, Cable Clamp, 0 - 1.75 Diameter	4
5	22-02336-02	Fuse, 5A	1

Remote Monitor, Sensor Kit - 75-Foot

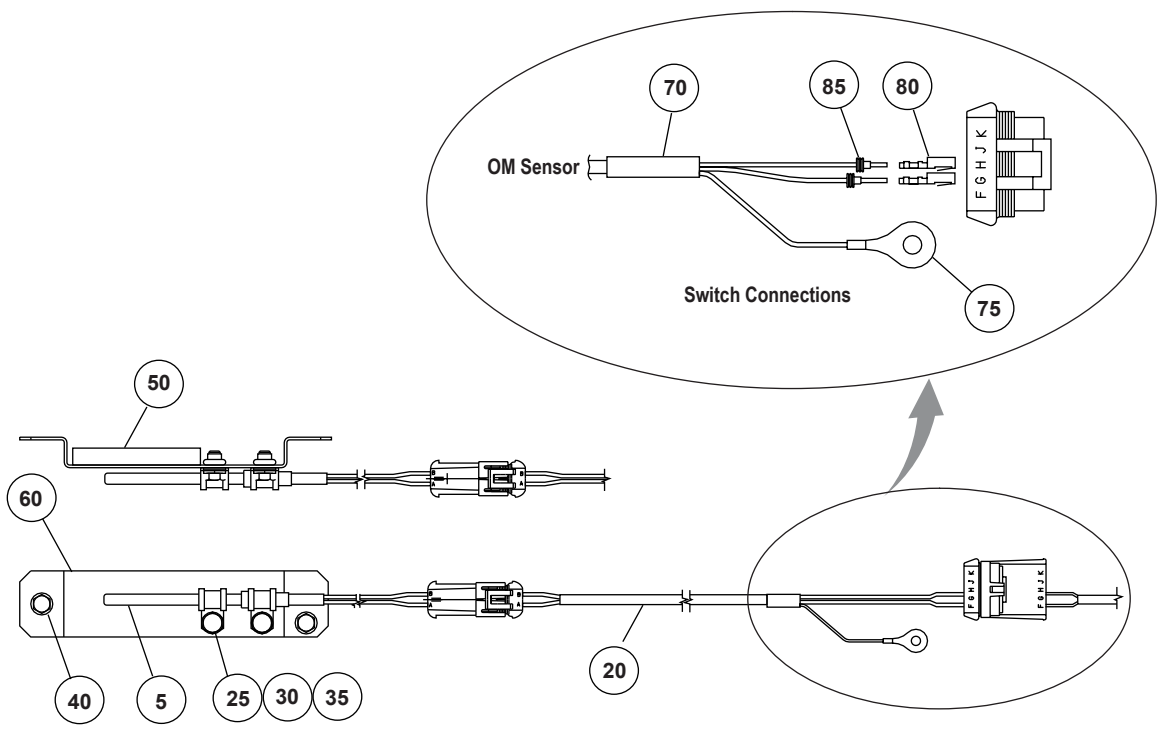

55 Sta-Strap, Cable Clamp (Not shown)

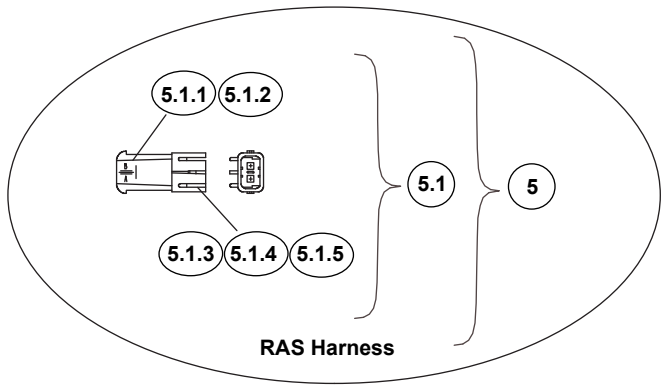
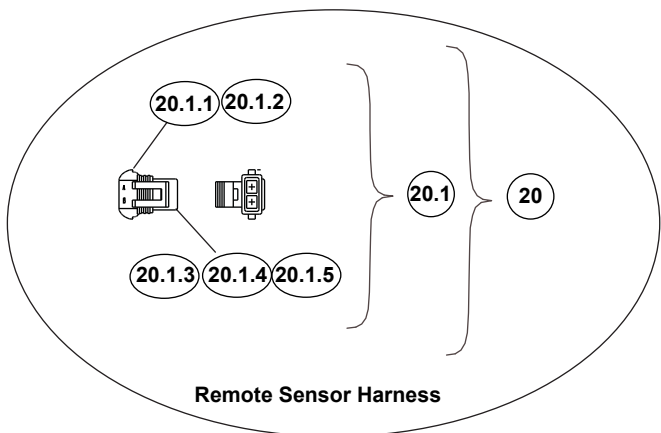

Item Number	Part Number	Part Description	Quantity
		Remote Monitor, Sensor Kit - Includes:	
5	22-01940-00	Harness, RAS, Includes:	1
5.1	22-50078-01SV	Connector Kit, Electrical, Includes:	1
5.1.1	22-50078-01	Connector, 2-Wire	1
5.1.2	22-50078-01A	Lock, Secondary	1
5.1.3	22-02394-02	Seal, Cable, Green	2
5.1.4	22-50078-47A	Terminal, Male	2
5.1.5	22-50078-47D	Terminal, Female	2
20	22-01857-00	Harness, Remote Sensor, Includes:	1
20.1	22-50078-02SV	Connector, Female, 2-Pin, Includes:	1
20.1.1	22-50078-02	Connector, 2-Wire	1
20.1.2	22-50078-01A	Lock, Secondary	1
20.1.3	22-02394-02	Seal, Cable, Green	2
20.1.4	22-50078-47A	Terminal, Male	2
20.1.5	22-50078-47D	Terminal, Female	2
25	34-00373-51	Clamp, Tube, 0.25 Diameter, Cushioned	22
30	34-00655-06	Screw, Cap, Hex Head, 1/4 - 20 x 0.75	2
35	34-00663-11	Washer, Lock, 1/4 Spring	2
40	34-01276-08	Screw, Hex Washer Head, 1/4 x 1.00, Self-Tapping	22
50	42-01170-01	Gasket	1
55	58-00079-02	Sta-Strap, Cable Clamp, 0 - 1.75 Diameter	5
60	67-00051-00	Bracket	1
70	22-02811-00	Terminal, Solder Sleeve	1
75	22-02812-00	Wire Assembly, Grade 12, Ring	1
80	22-50078-46B	Terminal, Female, 18 - 20 AWG, 150M/P	2
85	22-50078-50B	Seal, 150 M/P	2

Remote Monitor, Sensor Kit - 100-Foot

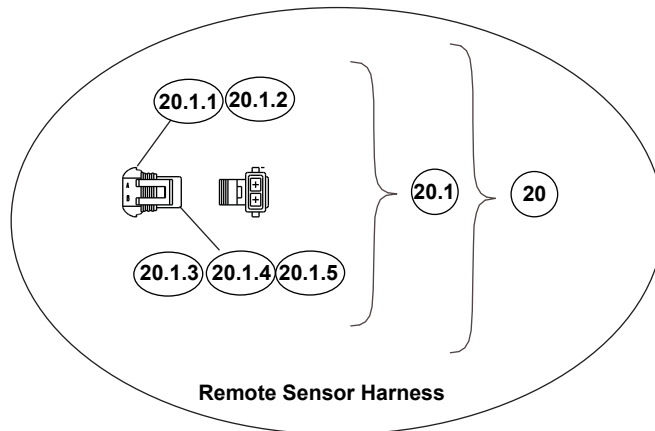
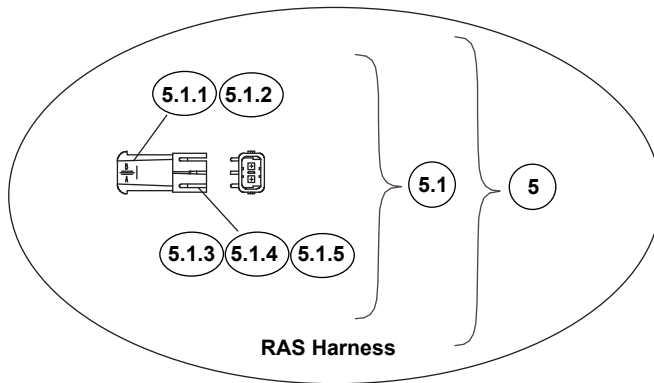
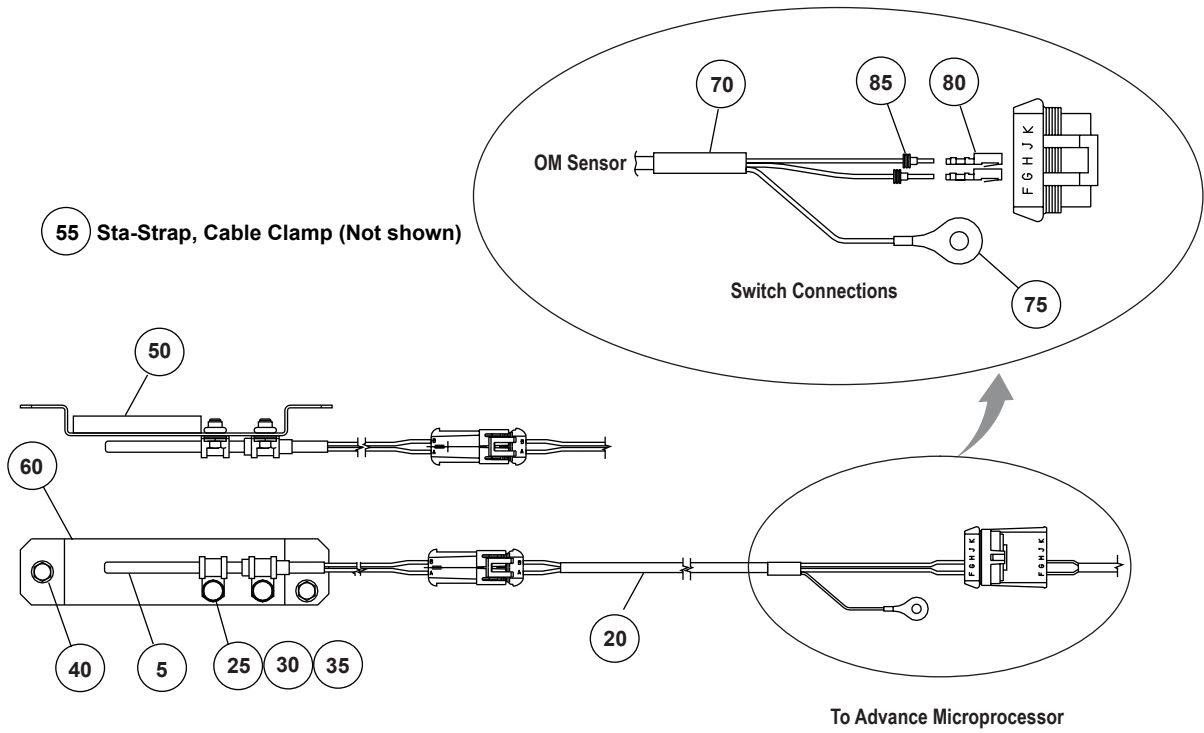

Item Number	Part Number	Part Description	Quantity
		Remote Monitor, Sensor Kit, 100 Foot-Includes:	
5	22-01940-00	Harness, RAS, Includes:	1
5.1	22-50078-01SV	Connector Kit, Electrical, Includes:	1
5.1.1	22-50078-01	Connector, 2-Wire	1
5.1.2	22-50078-01A	Lock, Secondary	1
5.1.3	22-02394-02	Seal, Cable, Green	2
5.1.4	22-50078-47A	Terminal, Male	2
5.1.5	22-50078-47D	Terminal, Female	2
20	22-01857-01	Harness, Remote Sensor, Includes:	1
20.1	22-50078-02SV	Connector, Female, 2-Pin, Includes	1
20.1.1	22-50078-02	Connector, 2-Wire	1
20.1.2	22-50078-01A	Lock, Secondary	1
20.1.3	22-02394-02	Seal, Cable, Green	2
20.1.4	22-50078-47A	Terminal, Male	2
20.1.5	22-50078-47D	Terminal, Female	2
25	34-00373-51	Clamp, Tube, 0.25 Diameter, Cushioned	22
30	34-00655-06	Screw, Cap, Hex Head, 1/4-20 x 0.75	2
35	34-00663-11	Washer, Lock, 1/4 Spring	2
40	34-01276-08	Screw, Hex Washer Head, 1/4 x 1.00, Self Tapping	22
50	42-01170-01	Gasket, 0.38 Thick	1
55	58-00079-02	Sta-Strap, Cable Clamp, 0-1.75 Diameter	5
60	67-00051-00	Bracket	1
70	22-02811-00	Terminal, Solder Sleeve	1
75	22-02812-00	Wire Assembly, Grade 12, Ring	1
80	22-50078-46B	Terminal, Female, 18-20 AWG, 150 M/P	2
85	22-50078-50B	Seal, 150 M/P	2

Remote Monitor, Pulp Probe Kit - Vector 8500 and 8600 units only

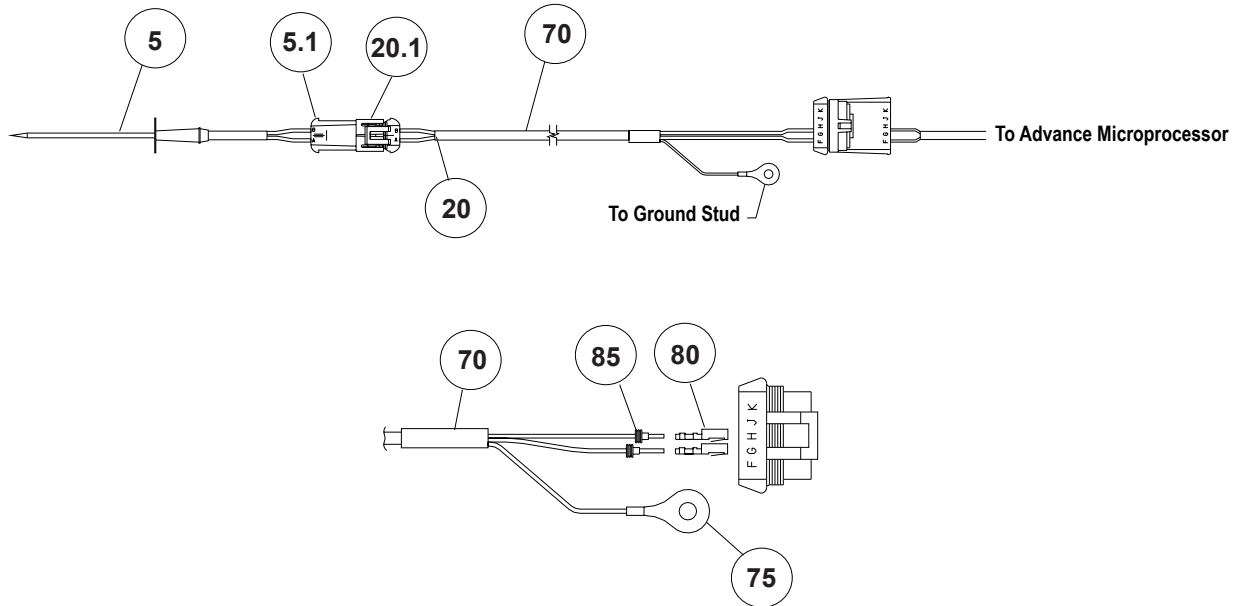

Item Number	Part Number	Part Description	Quantity
		Remote Monitor, Pulp Probe Kit - Includes:	
5	22-02809-00	Harness, Pulp Probe, Includes:	1
5.1	22-50078-01SV	Connector Kit, Electrical, Includes:	1
NS	22-50078-01	Connector, 2-Wire	1
NS	22-50078-01A	Lock, Secondary	1
NS	22-02394-02	Seal, Cable, Green	2
NS	22-50078-47A	Terminal, Male	2
NS	22-50078-47D	Terminal, Female	2
20	22-01857-00	Harness, Remote Sensor, Includes:	1
20.1	22-50078-02SV	Connector, Female, 2-Pin, Includes:	1
NS	22-50078-02	Connector, 2-Wire	1
NS	22-50078-01A	Lock, Secondary	1
NS	22-02394-02	Seal, Cable, Green	2
NS	22-50078-47A	Terminal, Male	2
NS	22-50078-47D	Terminal, Female	2
25	34-00373-51	Clamp, Tube, 0.25 Diameter, Cushioned	20
40	34-01276-08	Screw, Hex Washer Head, 1/4 x 1.00, Self Tapping	20
55	58-00079-02	Sta-Strap, Cable Clamp, 0 - 1.75 Diameter	5
70	22-02811-00	Terminal, Solder Sleeve	1
75	22-02812-00	Wire Assembly, Grade 12, Ring	1
80	22-50078-46B	Terminal, Female, 18 - 20 AWG, 150 M/P	2
85	22-50078-50B	Seal, 150 M/P	2

Remote Monitor, Door Switch Kit

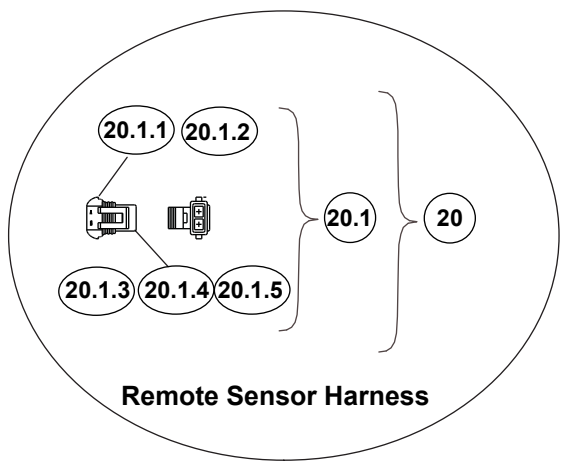
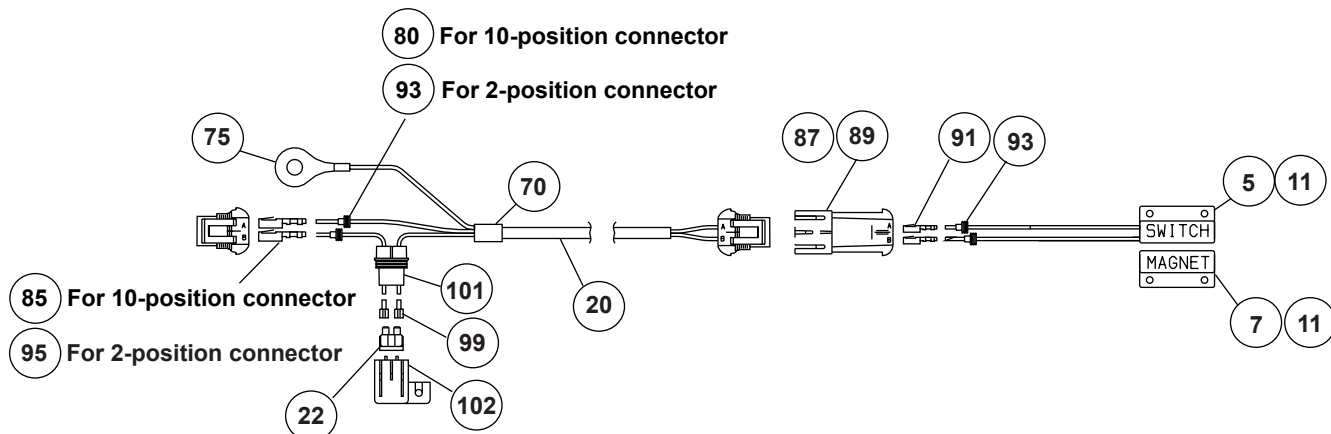

- (25) Clamp, Tube, 0.25 Diameter (Not shown)
- (40) Screw, Hex Washer Head, 1/4 x 1.00 (Not shown)
- (55) Sta-Strap., Cable Clamp (Not shown)

Item Number	Part Number	Part Description	Quantity
		Remote Monitor, Door Switch Kit - Includes:	
5	12-00419-03	Magnet, Door Switch	1
7	12-00419-04	Switch, Magnetic Door	1
11	34-06109-08	Screw, Thread Forming, Hex Head, 10-16 x 1.00	4
20	22-01857-00	Harness, Remote Sensor - Includes:	1
20.1	22-50078-02SV	Connector, Female, 2-Pin - Includes:	1
20.1.1	22-50078-02	Connector, 2-Wire	1
20.1.2	22-50078-01A	Lock, Secondary	1
20.1.3	22-02394-02	Seal, Cable, Green	2
20.1.4	22-50078-47A	Terminal, Male	2
20.1.5	22-50078-47D	Terminal, Female	2
22	22-02336-03	Fuse, 3A	1
25	34-00373-51	Clamp, Tube, 0.25 Diameter, Cushioned	22
40	34-01276-08	Screw, Hex Washer Head, 1/4 x 1.00, Self-Tapping	22
55	58-00079-02	Sta-Strap, Cable Clamp, 0-1.75 Diameter	5
70	22-02811-00	Terminal, Solder Sleeve	1
75	22-02812-00	Wire Assembly, Grade 12, Ring	1
80	22-50078-46B	Terminal, Female, 18-20 AWG, 150 M/P	2
85	22-50078-50B	Seal, 150 M/P	2
87	22-50078-01	Connector, Male, 2M 280 M/P	1
89	22-50078-01A	Lock, Secondary, 2M 280 M/P	1
91	22-50078-47A	Terminal, Male, 18-20 AWG, 280 M/P	2
93	22-02394-03	Seal, 0.06-0.09, Cable,	4
95	22-50078-47D	Terminal, Female, 18-20 AWG, 280 M/P	2
99	22-50078-49K	Terminal, Female, 18-20 AWG, 630M/P P2S	2
101	22-50078-22A	Fuse Holder, 2F M/P 630 P2S	1
102	22-50078-23	Fuse Holder, Cover	1

Low Fuel Sensor, 22" Diameter Tank - Vector 8500 and 8600 units only

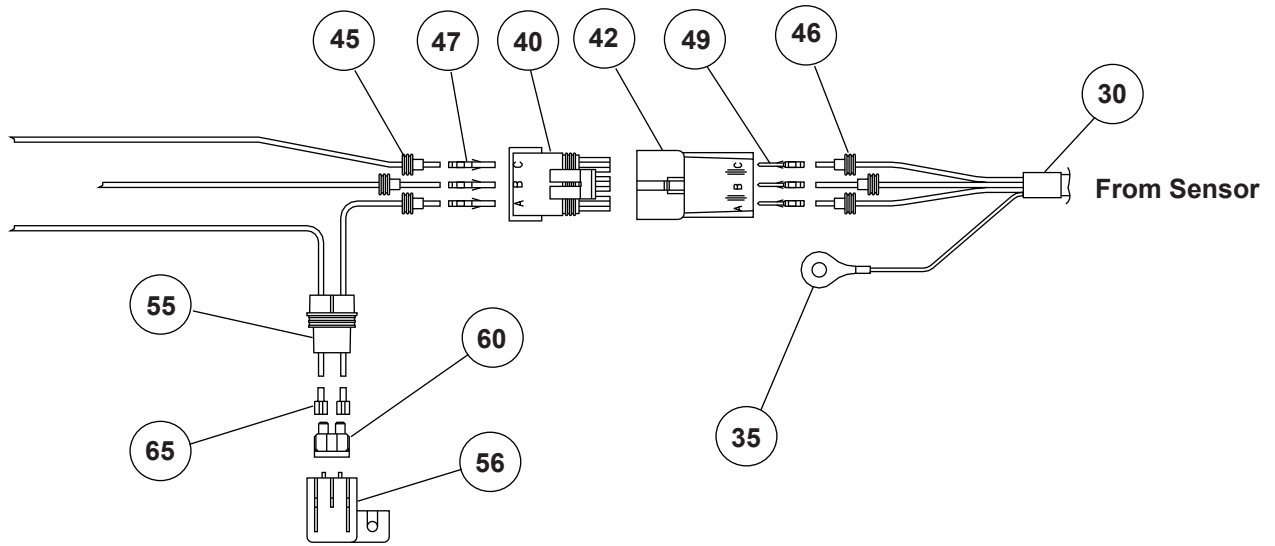

Sensor Connections

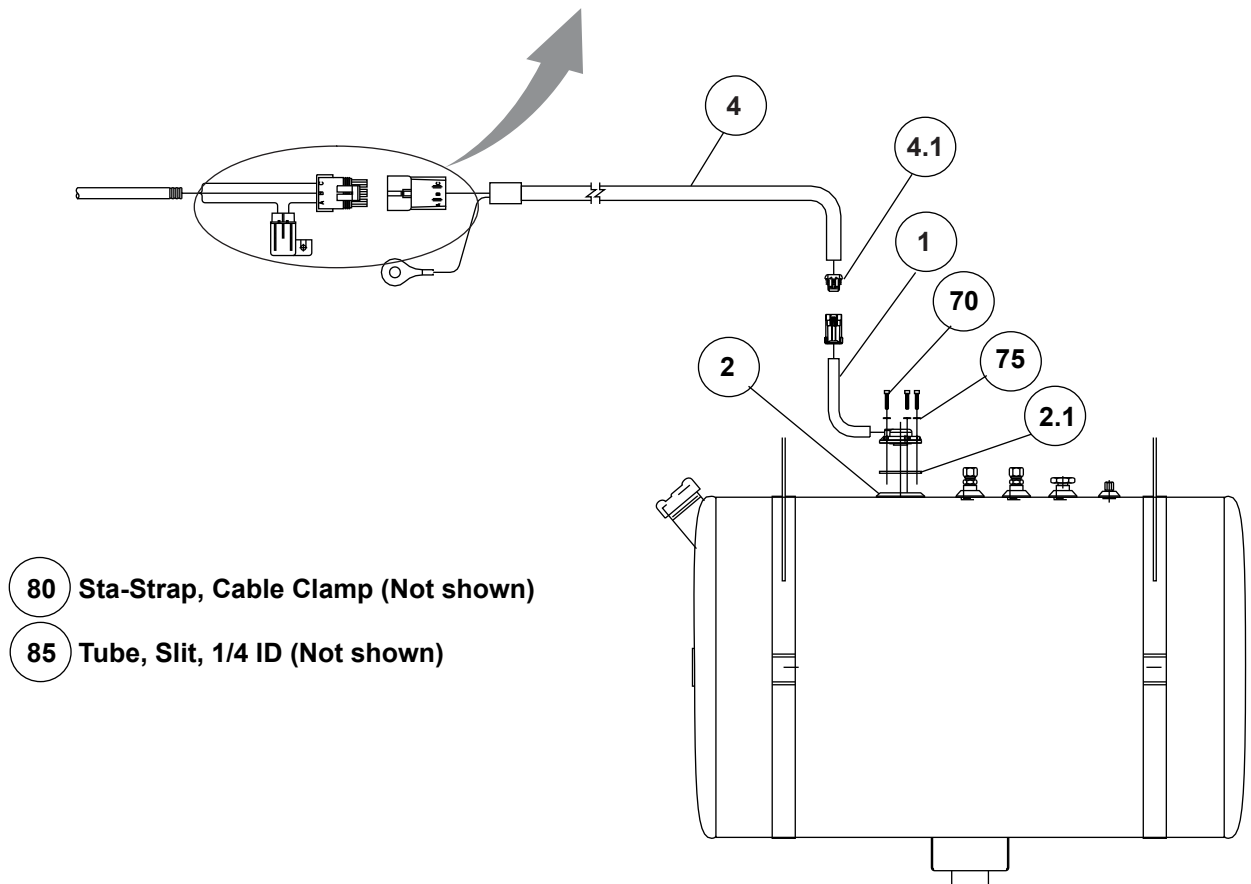

80 Sta-Strap, Cable Clamp (Not shown)

85 Tube, Slit, 1/4 ID (Not shown)

Item Number	Part Number	Part Description	Quantity
		Low Fuel Sensor, 22 Inch Diameter Tank - Includes:	
1	12-00675-00	Sensor, Fuel Level	1
2	12-00675-51	Tube, Focus, Gasket, 22 Inch, Includes:	1
2.1	12-00675-50	Gasket	1
4	22-02892-00	Wire Harness, Fuel Level Sensor, Includes:	1
4.1	22-50078-24	Connector, Female, 3-Pin	1
30	22-02811-00	Terminal, Solder Sleeve	1
35	22-02812-00	Wire Assembly, Grd, 12 Inch, Ring	1
40	22-50098-59	Connector, Female, 3F W/P TWR	1
42	22-50098-60	Connector, Male, 3M W/P SHD	1
45	22-02394-02	Seal, 0.08-0.11 Cable OD	3
46	22-02394-03	Seal, 0.06-0.09 Cable OD	6
47	22-50078-58F	Terminal, Female, 18-20 AWG W/P	3
49	22-02393-01	Terminal, Male. 18-20 AWG	3
55	22-50078-22A	Fuse, Holder, 2F M/P 630 P25	3
56	22-50078-23	Fuse, Holder, Cover	1
60	22-02336-03	Fuse, 3A	1
65	22-50078-49K	Terminal, Female, 18-20 AWG 630 M/P P25	2
70	34-00662-09	Washer, Plain, Number 10, Medium, 0.32 Thick	5
75	34-01323-16	Screw, Socket Head, Number 10-32 x 1.00	5
80	58-00079-02	Sta-strap, Cable Clamp, 0-1.75 Diameter	2
85	58-00858-00	Tube, Slit, 1/4 ID, Bulk Corrugated	0.6667

Low Fuel Sensor, 36.5" Diameter Tank - Vector 8500 and 8600 units only

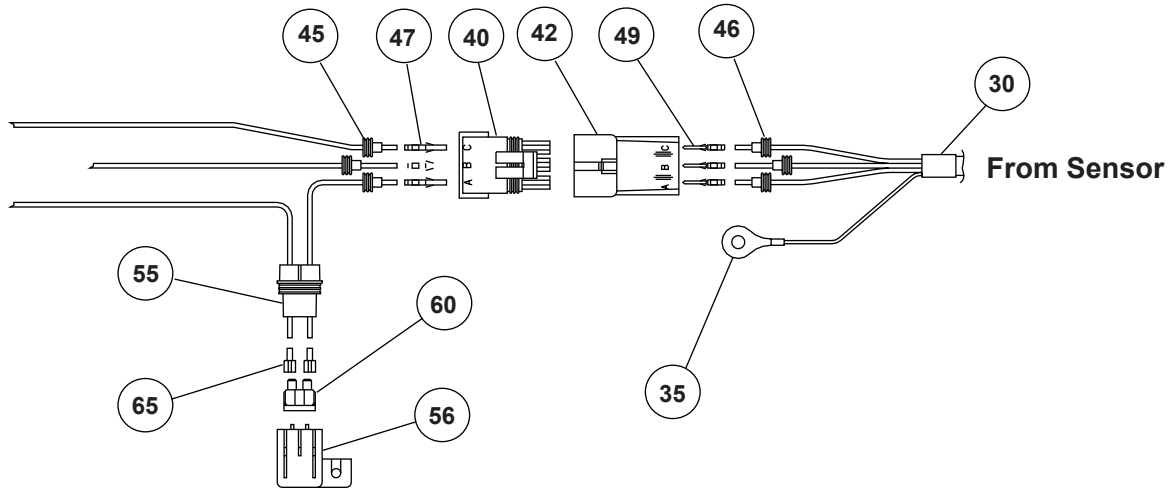

Sensor Connections

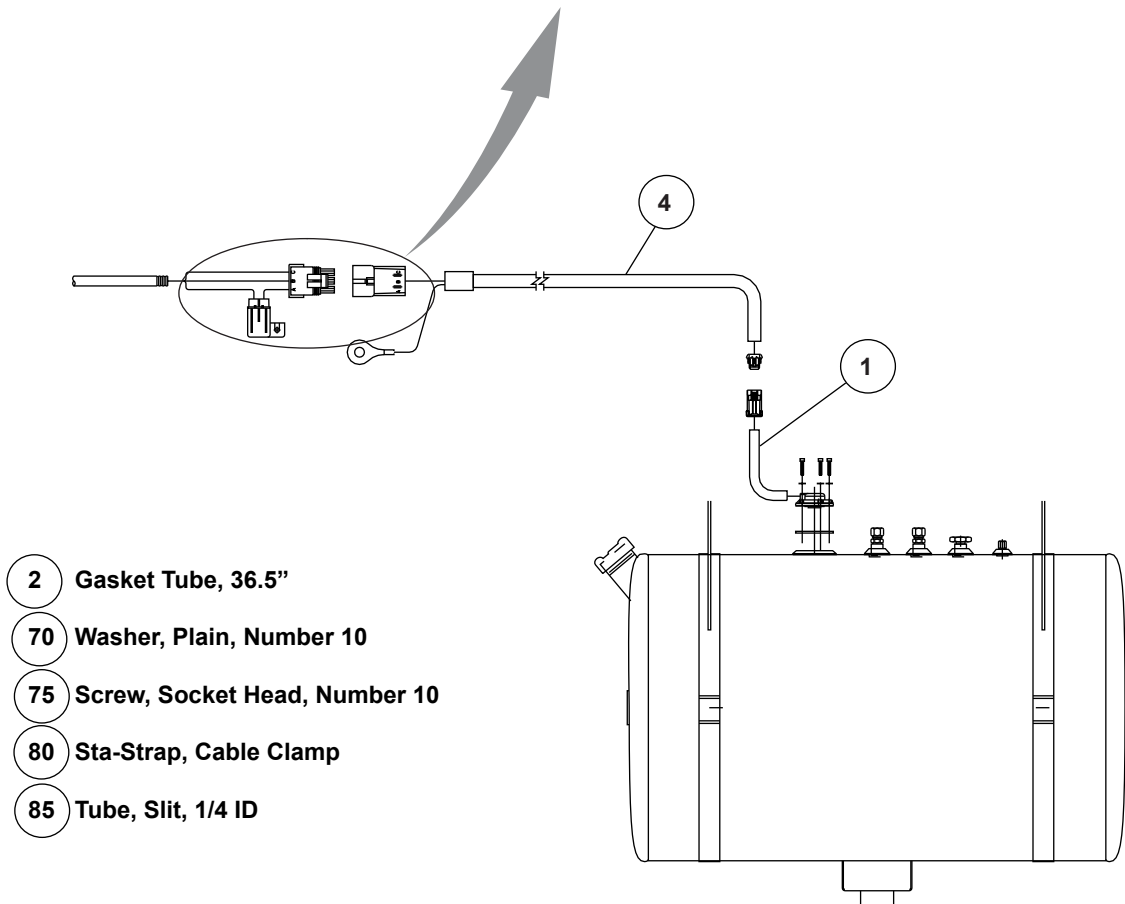

- 2 Gasket Tube, 36.5"
- 70 Washer, Plain, Number 10
- 75 Screw, Socket Head, Number 10
- 80 Sta-Strap, Cable Clamp
- 85 Tube, Slit, 1/4 ID

Item Number	Part Number	Part Description	Quantity
		Low Fuel Sensor, 36.5 Inch Diameter Tank-Includes:	
1	12-00675-01	Sensor, Fuel Level	1
2	12-00675-52	Tube, Focus, Gasket, 36.5 Inch, Includes:	1
2.1	12-00675-50	Gasket	1
4	22-02892-00	Wire Harness, Fuel Level Sensor	1
4.1	22-50078-24	Connector, Female, 3-Pin	1
30	22-02811-00	Terminal Solder Sleeve	1
35	22-02812-00	Wire Assembly, Grd, 12 Inch, Ring	1
40	22-50098-59	Connector, Female, 3F W/P TWR	1
42	22-50098-60	Connector, Male, 3M W/P SHD	1
45	22-02394-02	Seal, 0.08-0.11, Cable OD	3
46	22-02394-03	Seal, 0.06-0.09, Cable OD	6
47	22-50078-58F	Terminal, Female, 18-20 AWG W/P	3
49	22-02393-01	Terminal, Male, 18-20 AWG	3
55	22-50078-22A	Fuse, Holder, 2F M/P 630 P25	1
56	22-50078-23	Fuse, Holder, Cover	1
60	22-02336-03	Fuse, 3A	1
65	22-50078-49K	Terminal, Female, 18-20 AWG 630 M/P P25	2
70	34-00662-09	Washer, Plain, Number 10 Medium, 0.32 Thick	5
75	34-01323-16	Screw, Socket Head, Number 10-32 x 1.00	5
80	58-00079-02	Sta-strap, Cable Clamp, 0-1.75 Diameter	2
85	58-00858-00	Tube, Slit, 1/4 ID, Bulk Corrugated	0.6667