

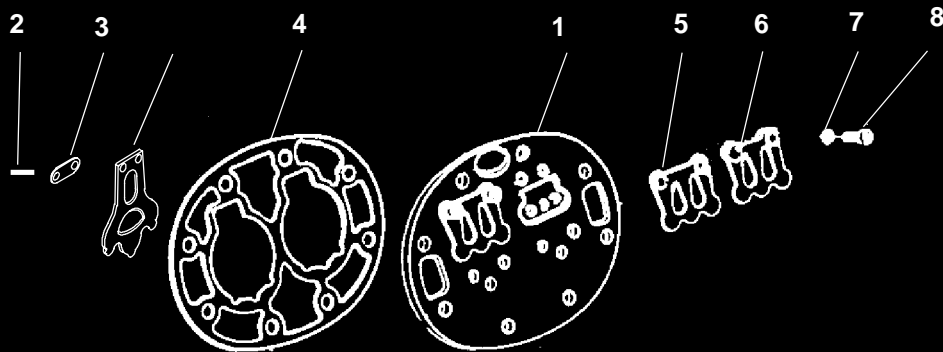

Compressor



SERVICE PARTS LIST
for
MODEL 05G COMPRESSOR
(Three Port Valve Plate)



TRANSICOLD

SERVICE PARTS LIST

MODEL 05G COMPRESSOR

(Three Port Valve Plate)

TABLE OF CONTENTS

INTRODUCTION	i
MODEL CHART	i
ORDERING INSTRUCTIONS	ii
GENERAL NOTES	ii
COMPRESSOR OIL CHART	ii
1 CRANKCASE AND SUCTION SERVICE VALVE	1
2 COMPRESSOR BASE GROUP	2
3 BEARING HEAD AND OIL PUMP	3
4 CRANKSHAFT, ROD AND PISTON GROUP	4
5 SHAFT END GROUP	5
6 SHAFT END FLANGES	6
7 CYLINDER HEADS	7
7.1 Side Cylinder Head	7
7.2 Center Cylinder Head	8
8 VALVE PLATE ASSEMBLY	9
9 UNLOADERS	10
10 UNLOADER KITS, BUS	13
10.1 Pressure To Electric Unloader Kit - R-134a ONLY - 24 VDC	13
10.2 Pressure To Electric Unloader Kit - R-22 ONLY - 24 VDC	14
10.3 Pressure To Electric Unloader Kit - R-134a ONLY - 36 VDC	14
10.4 Pressure To Electric Unloader Kit - R-22 ONLY - 36 VDC	14
11 GASKET SETS	15
11.1 Fiber Universal Gasket Set	15
11.2 Metal Gasket Set	16
12 CLUTCH ASSEMBLIES	17
12.1 Shaft Mounted Clutch Assembly	17
12.2 Housing Mounted (Warner - Gray In Color) Clutch Assembly	18
12.3 Housing Mounted (Linnig - Gold In Color) Clutch Assembly	20
PART NUMBER INDEX	Index-1

INTRODUCTION

This parts list identifies service replacement parts for the 05G Compressors listed in the Model Chart below. To find replacement parts, determine the major group in which the replacement parts are located (refer to the Table of Contents) and turn to the appropriate page for the illustrated parts breakdown of the replacement parts. A detailed list of the tools needed to service the 05G Compressor may be found in the Service Tool List catalog 62-03213.

MODEL CHART

MODEL	PART NO.	COMPRESSOR CONFIGURATION	APPLICATION
05GX-37CFM	18-00059-126RM	Ultra Bottom Cover, 37 CFM , Contoured Pistons, Ultra Flange, 2 Unloader Heads (Bypass Plugs Installed), No Oil	Trailer
05GX-41CFM	18-00059-72RM	Ultra Bottom Cover, 41 CFM , Contoured Pistons, Ultra Flange, 2 Electric Unloaders, Installed No Oil	Trailer
05GX-37CFM	18-00059-130RM	Standard Bottom Cover, 37 CFM , Contoured Pistons, Star Flange, 1 Unloader Head (Bypass Plug Installed), No Oil	Truck (Supra 9XX)
05GX-37CFM	18-00059-128RM	Ultra Bottom Cover, 37 CFM , Contoured Pistons, Ultra Flange With Threaded Clutch Hub, 2 Unloader Heads (Bypass Plugs Installed), No Oil	Trailer With Standby
05GX-37CFM	18-00059-169	Standard Bottom Cover, 37 CFM , Flat Pistons, Half Moon Flange With Hub, 2 Unloader Heads (Bypass Plugs Installed), 7.5 Pints Alkyl Benzene Oil	Bus (R-22)
05GX-41CFM	17-44062-00	Standard Bottom Cover, 41 CFM , Flat Pistons, Half Moon Flange With Hub, 2 Unloader Heads (Bypass Plugs Installed), 5.8 Pints Polyolester (POE) Oil	Bus (R-134a)
05GT937B11-A	17-44065-00	Standard Bottom Cover, 37 CFM , Flat Pistons, Half Moon Flange With Hub, 2 Unloader Heads (Bypass Plugs Installed), Crankshaft Parko Lubrite Coated, No Oil	Bus
05GX637111	17-44053-02	Standard Bottom Cover, 37 CFM , Flat Pistons, Half Moon Flange, 2 Unloader Heads (Bypass Plugs Installed), 7 Pints Mineral Oil	Bus (R-22)

ORDERING INSTRUCTIONS

All orders and inquiries for parts must include: Unit Serial Number, Part Number, description of part as shown on list and quantity required. Address all correspondence for parts to the following address:

CARRIER TRANSICOLD DIVISION
Performance Parts Group, TR-20
P.O. Box 4805, Syracuse, NY 13221.
or
Fax to: (315) 432-3778

GENERAL NOTES

To find replacement parts consult table of contents, and turn to the appropriate page for the illustrated breakdown of replacement parts. The following letter designations are used to classify parts throughout this list.

A/R *As Required*

NSA *Non-Stock Assembly* - order components listed under the assembly.

NSS *Not Sold Separately* - order next higher assembly or kit.

NLO *No Longer Offered* - order replacement part or assembly

COMPRESSOR OIL CHART

Part Number	Oil Type	Viscosity	Refrigerants	Application	Packaging
07-00275-00	Mineral	150	R-12, R-22, R-500, R-502	Large Bus	1 Gallon x 6
07-00377-00	Mineral	300	R-12, R-22, R-500	Large Bus	1 Gallon x 6
07-00430-00	Alkyl Benzene (A/B)	68	R-22	Large Bus	1 Gallon x 6
07-00274-00	Alkyl Benzene (A/B)	150	R-12, R-22, R-500, R-502	Trailer	1 Gallon x 6
07-00317-00PK6	Polyolester (POE)	68	R-134a, R-404a	Truck, Trailer, and Large Bus	1 Gallon x 6

NOTE

Refer to the unit operation and service manual for the correct procedure for checking compressor oil level.

1. CRANKCASE AND SUCTION SERVICE VALVE

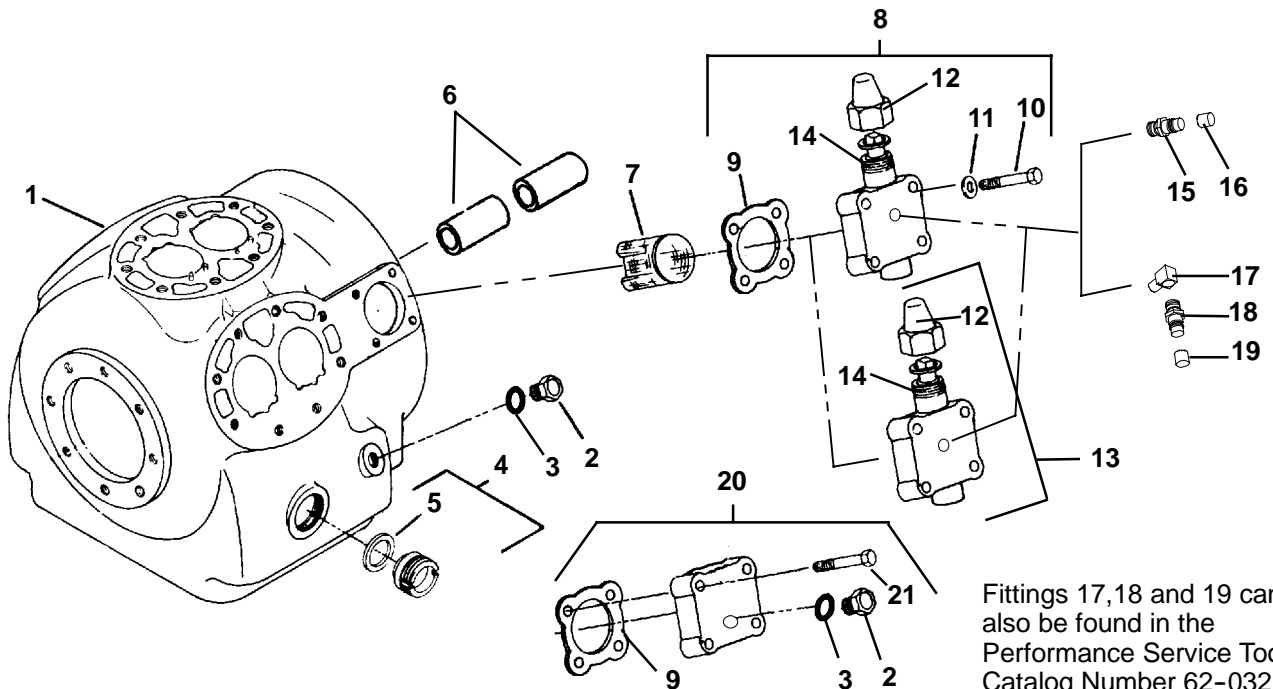

Item	Part Number	Description	Qty
1	NSA	Crankcase	1
2	CA63AA051	Pipe Plug, 1/4-18 NPT (Package of 20)	1
	17-44037-00	Plug, O-Ring, 7/16-20 - Includes:	
3	42-00243-07	O-Ring	1
4	17-10218-00	Sight Glass, Oil Level - Includes:	2
	17-10218-02	Gasket (Fiber)	
5	17-44021-00	Gasket (Metal)	1
	17-10218-02	Gasket (Fiber)	
6	17-44015-00	Bearing, Main Seal End (Requires Line Boring)	2
7	17-44005-00	Strainer, Suction	1
8	17-31062-00	Valve, Service, 1-1/8 ODF (Bus/Supra 9xx) - Includes:	1
9	17-40005-05	Gasket, Service Valve (Fiber)	1
10	17-13020-00	Capscrew, 1/2-13 x 2-1/2 Inches Long - SAE Grade 5	4
11	17-40007-00	Gasket, Capscrew, 1/2 Inch	4
12	17-10812-01	Cap, Service Valve (Plastic) (With Relief Hole)	1
	17-10806-10	Cap, Service Valve (Brass)	
13	17-40002-01	Valve, Service, 1-3/8 ODF (Truck/Trailer) - Includes:	1
12	17-10812-01	Cap, Service Valve (Plastic) (With Relief Hole)	1
	17-10806-10	Cap, Service Valve (Brass)	
9	17-44141-00	Gasket, 4 Bolt Service Valve (Metal -May be used in place of fiber gasket)	1
14	34-50022-00	Packing Kit, Service Valve Stem (4- Bolt)	1
15	06DA403844	Valve, Access (1/4 Flare, Schrader) (for R-12, R-22, R-404A)	1
16	DD19CA061	Cap, 1/4 Flare, Schrader	1
17	40-00524-00	Elbow, 1/4 NPT x M13, Brass (for R-134a)	1
18	40-00520-00	Coupling, M13, R-134a, Brass - Includes:	1
19	40-00520-02	Cap, Service Port	1
20	17-13006-00	Kit, Valve Pad Blank Off, 4 Bolt Suction Service Valve - Includes:	1
2	17-44037-00	Plug, O-Ring, 7/16-20 - Includes:	1
3	42-00243-07	O-Ring	1
9	17-40005-05	Gasket, Service Valve (Fiber)	1
21	AA06BR293	Capscrew, 1/2-13 x 1-1/2 Inches Long - SAE Grade 5	4

2. COMPRESSOR BASE GROUP

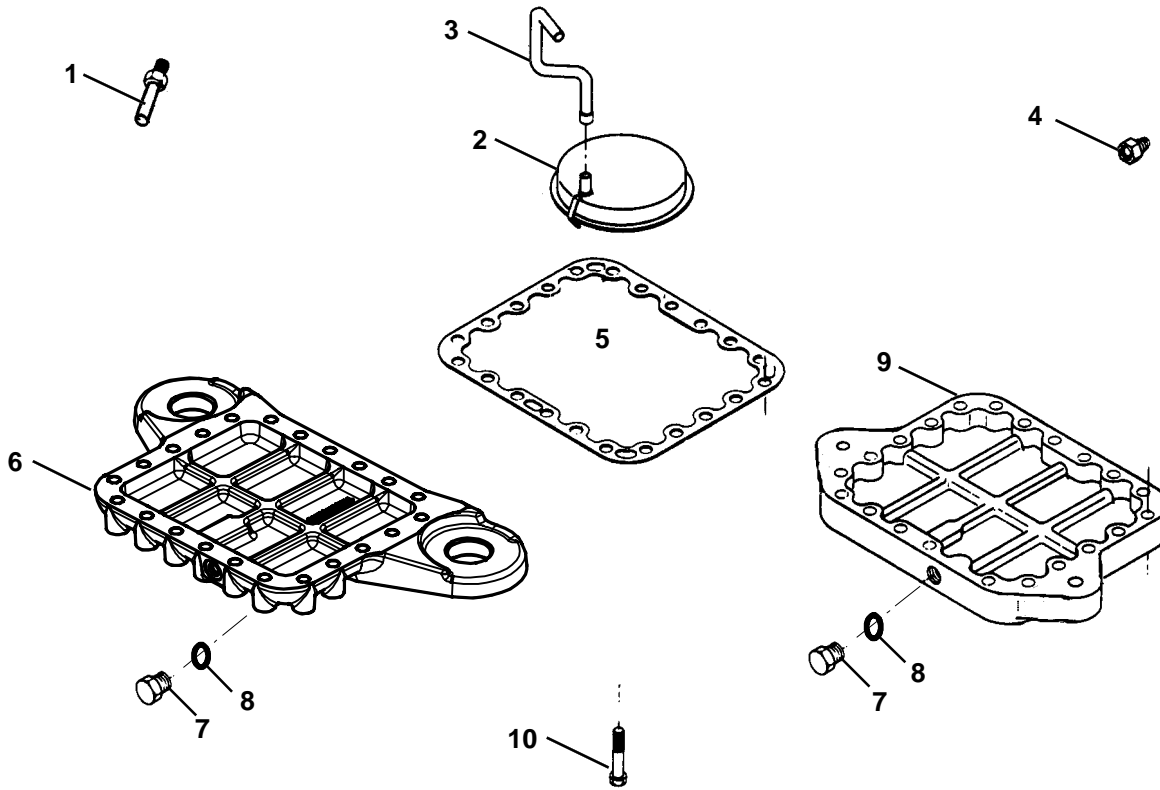

Item	Part Number	Description	Qty
1	17-44011-00	Oil Relief Valve	1
2	17-40020-00	Oil Filter Screen Assembly	1
3	17-40021-00	Tube, Oil Suction	1
4	17-40042-00	Oil Return Check Valve Assembly	2
5	17-44129-00	Gasket, Bottom Plate (Metal)	1
6	17-44026-00	Plate, Bottom, Aluminum, (Ultra Style Compressors)	1
7	CA63AA051	Pipe Plug, 1/4-18 NPT (Package of 20)	1
	17-44037-00	Plug, O-Ring, 7/16-20 - Includes:	
8	42-00243-07	O-Ring	1
9	17-44035-00	Plate, Bottom, Aluminum, (Non-Ultra Style Compressors)	1
7	17-44037-00	Plug, O-Ring, 7/16-20 - Includes:	1
8	42-00243-07	O-Ring	1
10	17-44117-00	Capscrew, Hex Head, 3/8-16 x 2-1/4 Inches Long - SAE Grade 8	22

3. BEARING HEAD AND OIL PUMP

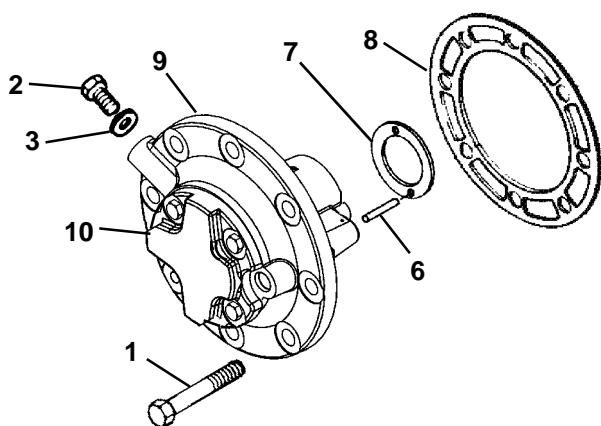
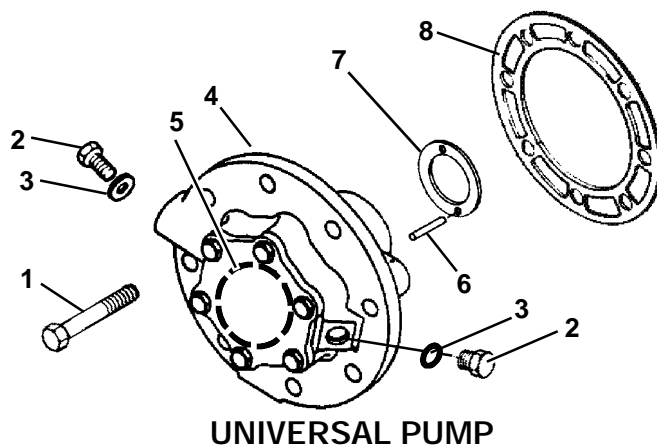

LOW PROFILE PUMP (NLO)

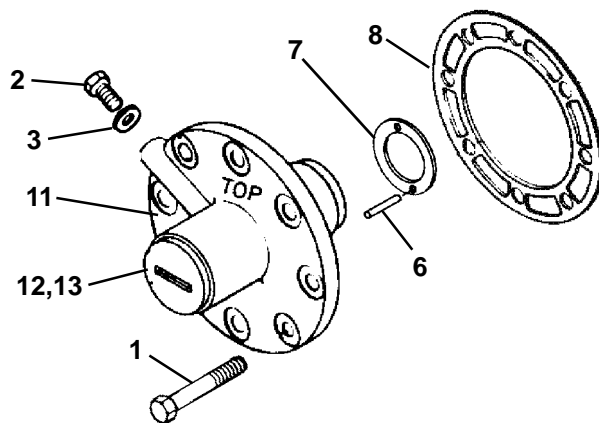

GEAR PUMP (NLO)

Item	Part Number	Description	Qty
1	17-10308-00	Capscrew, Hex Head, 3/8-16 x 1-1/4 Inches Long - SAE Grade 5	8
2	17-44037-00	Plug, O-Ring, 7/16-20 - Includes:	1
3	42-00243-07	O-Ring	1
4	17-44137-00	Oil Pump and Bearing Head (Universal Gear Pump)	1
5	17-44139-00	O-Ring, Pump Cover Plate	1
6	17-40204-00	Pin, Roll, 1/8 x 1/2 Inch	2
7	17-55009-01	Thrustwasher, Pump End	1
8	17-40078-05	Gasket, Bearing Head (Fiber)	1
	17-44022-00	Gasket, Bearing Head (Metal)	1
9	SEE NOTE	Oil Pump and Bearing Head Assembly (Low Profile Gear Pump)	1
10	42-00045-01	O-Ring	1
11	SEE NOTE	Oil Pump and Bearing Head Assembly (Gear Pump) - Includes:	1
12	17-44033-01	Cover Assembly, Screw - Includes:	1
13	17-44033-02	Gasket, O-Ring	1

NOTE: Low Profile and Gear Oil Pump Bearing Head Assemblies are no longer offered, use the Universal Gear Pump (Item 4) to replace entire oil pump assembly.

4. CRANKSHAFT, ROD AND PISTON GROUP

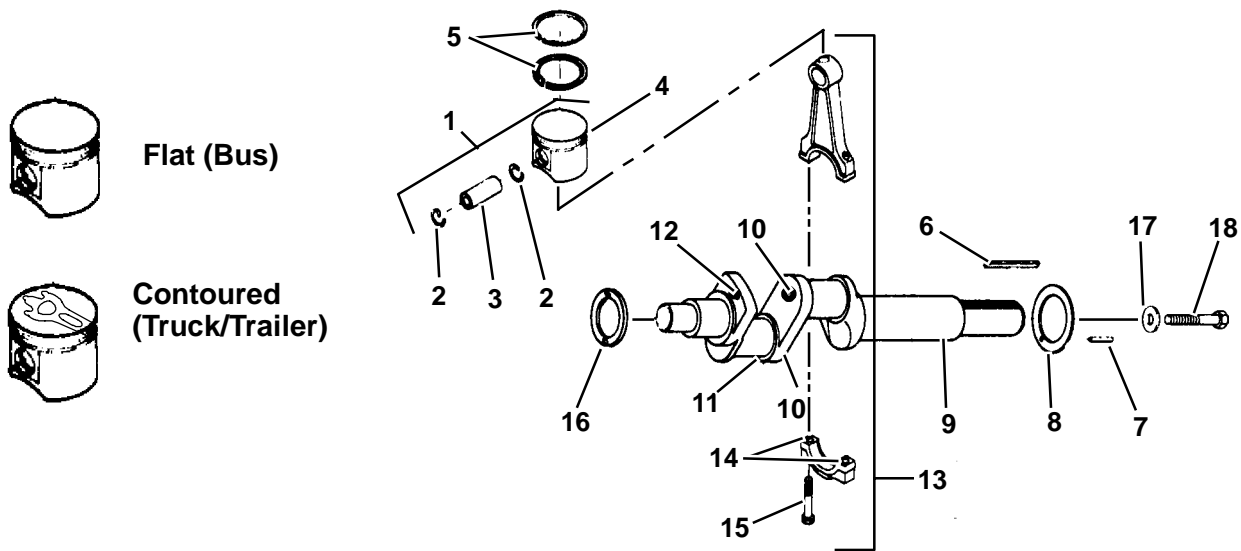

Item	Part Number	Description	Qty
1	17-44045-01	Piston, 05G37 CFM, Flat , Standard - Includes:	6
	17-44045-03	Piston, 05G37 CFM, Flat , .020 Inch Oversize - Includes:	
	17-44121-01	Piston, 05G41 CFM, Flat , Standard - Includes:	
	17-44122-01	Piston, 05G41 CFM, Flat , .020 Inch Oversize - Includes:	
1	17-44016-05	Piston, 05G37 CFM, Contoured , Standard - Includes:	6
	17-44016-07	Piston, 05G37 CFM, Contoured , .020 Inch Oversize - Includes:	
	17-44115-01	Piston, 05G41 CFM, Contoured , Standard - Includes:	
	17-44115-20	Piston, 05G41 CFM, Contoured , .020 Inch Oversize - Includes:	
2	17-40053-00	Retainer, Piston Pin	2
3	NSS	Pin, Piston	1
4	NSS	Piston	1
5	17-40055-00	Ring, Compression (Standard)	12
	17-55025-00	Ring, Compression (.020 Inch Oversize)	12
	17-40054-00	Ring, Oil (Used W/ Older O5G37 Piston W/ Wider Lower Ring Groove)	A/R
6	17-40324-00	Key, Crankshaft, 1/4 x 1/4 x 1-1/2 Inches Long (For Shaft Mounted or No Clutch)	1
	68G2-9072	Key, Crankshaft (For Housing Mounted Clutch)	
7	17-44036-00	Pin, Spiral, 1/8 x 1/2 Inch Long	2
8	17-44008-00	Thrustwasher, Seal End	1
9	17-44074-00	Crankshaft Assembly, 05G37 CFM (05G Twin Port) - Includes:	1
	17-44075-00	Crankshaft Assembly, 05G41 CFM (05G Twin Port) - Includes:	
10	17-40317-00	Expansion Plug	2
11	AF55CQ164	Setscrew, 1/4-28 x 1/2 Inch Long	1
12	34-00300-07	Capscrew, Hex Head, 1/4-20 x 7/8 Inch Long - Grade 5	1
13	17-40056-02	Connecting Rod and Cap Assembly (Standard) - Includes:	6
	17-55023-00	Connecting Rod and Cap Assembly (.010 Inch Undersize) - Includes:	
14	17-40057-00	Pin, Dowel	2
15	17-55008-00	Capscrew (Special)	2
16	17-55009-01	Thrustwasher, Pump End	1
17	34-00616-00	Washer, 13/32 ID x 1-1/2 OD x 3/16 Thick	1
18	34-00613-07	Capscrew, Hex Head, 3/8-24 UNF x 7/8 Inch Long - SAE Grade 8	1

5 SHAFT END GROUP

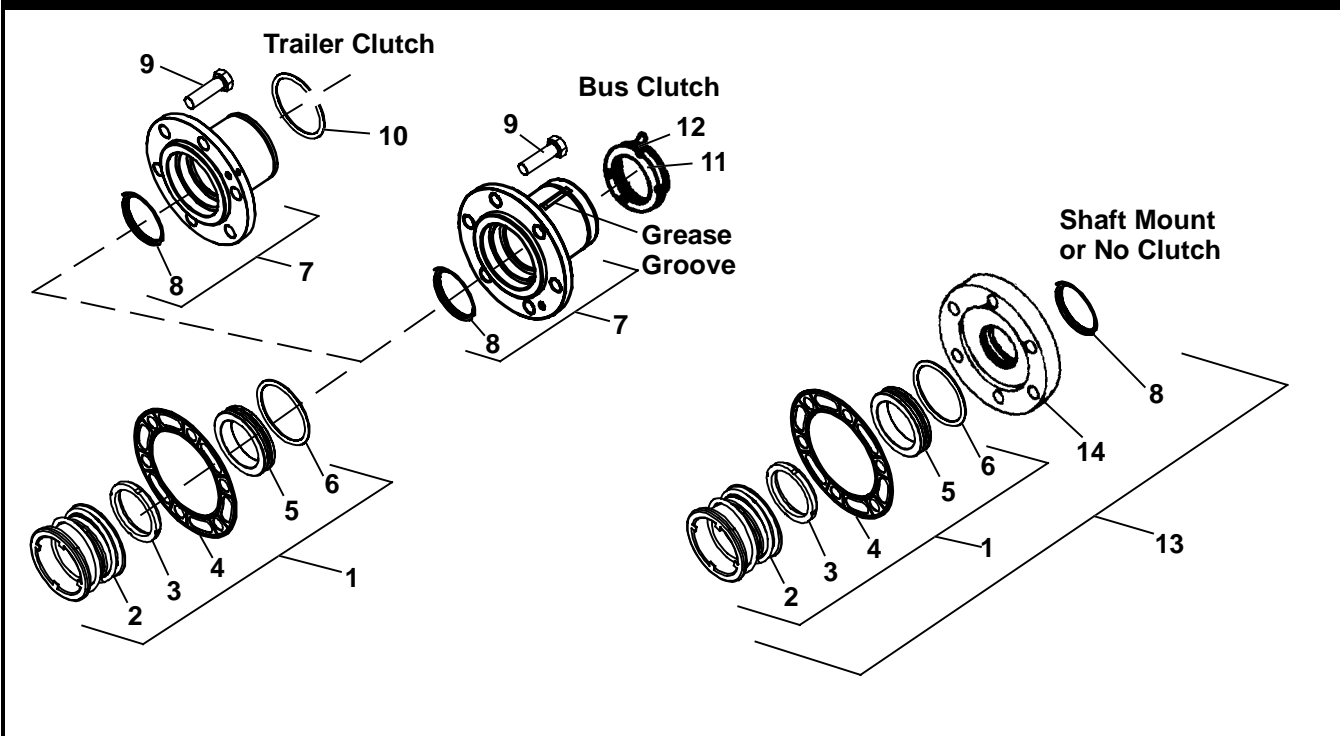

Item	Part Number	Description	Qty
1	17-44770-00	Seal Assembly (Shaft) - Includes:	1
2	NSS	Spring And Bellows Assembly, Shaft Seal	1
3	NSS	Rotor, Seal	1
4	17-44004-06	Gasket, Seal Cover - (Metal)	1
5	NSS	Stator, Seal, (Wear Ring)	1
6	17-44043-02	O-Ring, Stator	1
7	17-44019-01	Hub Assembly, Housing Mounted Clutch, Groove, Snap Ring - Trailer - Includes:	1
	17-44041-01	Hub Assembly, Housing Mounted Clutch, Threaded, W/Grease Groove - Bus - Includes:	
8	17-44042-00	Felt Ring	1
9	17-40308-00	Capscrew, 3/8-16 X 1-1/4 Inch Long Grade 5	6
10	50-00221-30	Ring, Snap	1
11	34-06083-00	Nut, Hub, Without Grease Fitting Port - Bus	1
	34-01161-00	Nut, Hub, With Grease Fitting Port - (Fitting Not Included) Bus	
12	40-01132-00	Fitting, Grease, 1/4-28 NPT- Bus	1
13	17-44145-00	Seal Assembly (Shaft Mounted Clutch) - Includes:	1
1	17-44770-00	Seal Assembly (Shaft) - Includes:	1
2	NSS	Spring And Bellows Assembly, Shaft Seal	1
3	NSS	Rotor, Seal	1
4	17-44004-06	Gasket, Seal Cover - (Metal)	1
5	NSS	Stator, Seal, (Wear Ring)	1
6	17-44043-02	O-Ring Used with Silicone Carbide	1
14	NSS	Seal Cover, Shaft	1
8	17-44042-00	Felt Ring	1
4	17-44004-06	Gasket, Seal Cover - (Metal)	1

6. SHAFT END FLANGES

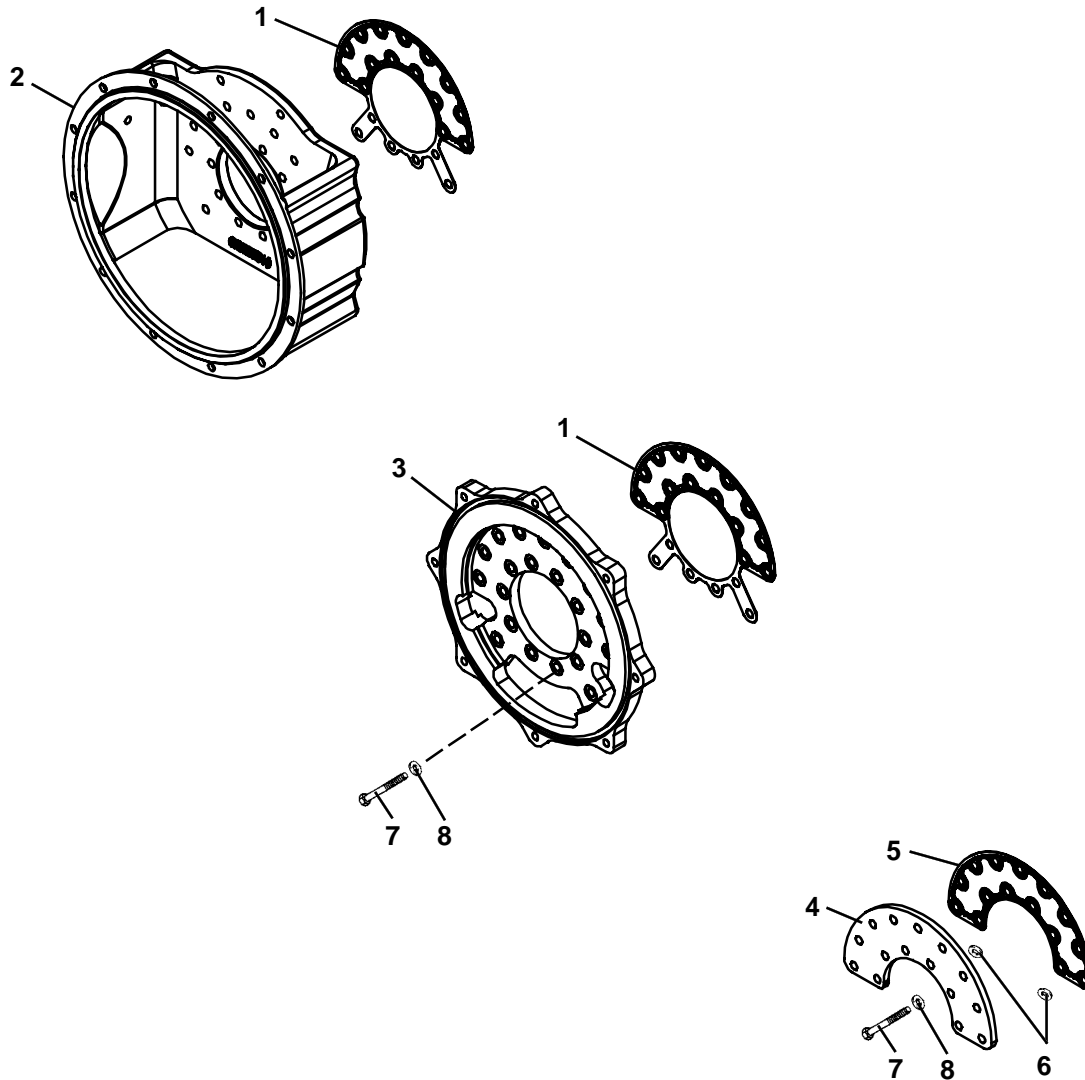

Item	Part Number	Description	Qty
1	17-44119-00	Gasket, End Flange, Ultra Style or Full Ring Flange (Used With Items 2 and 3)	1
2	17-44025-00	End Flange, Ultra Style (Trailer)	1
3	17-44002-00	End Flange, Full Ring (Star Flange)	1
4	17-44127-00	End Flange, Half Moon (Bus)	1
5	17-44118-00	Gasket, Half Moon End Flange (Used Only With Item 4)	1
6	17-44014-00	Gasket, Flange Spacer (Used Only With Items 4 and 5)	2
7	17-10308-00	Cap Screw, Hex Head, 3/8-16 X 1.25 Inch Long, Grade 5	A/R
8	17-40019-00	Gasket, Cap Screw	A/R

7. CYLINDER HEADS

7.1 Side Cylinder Head

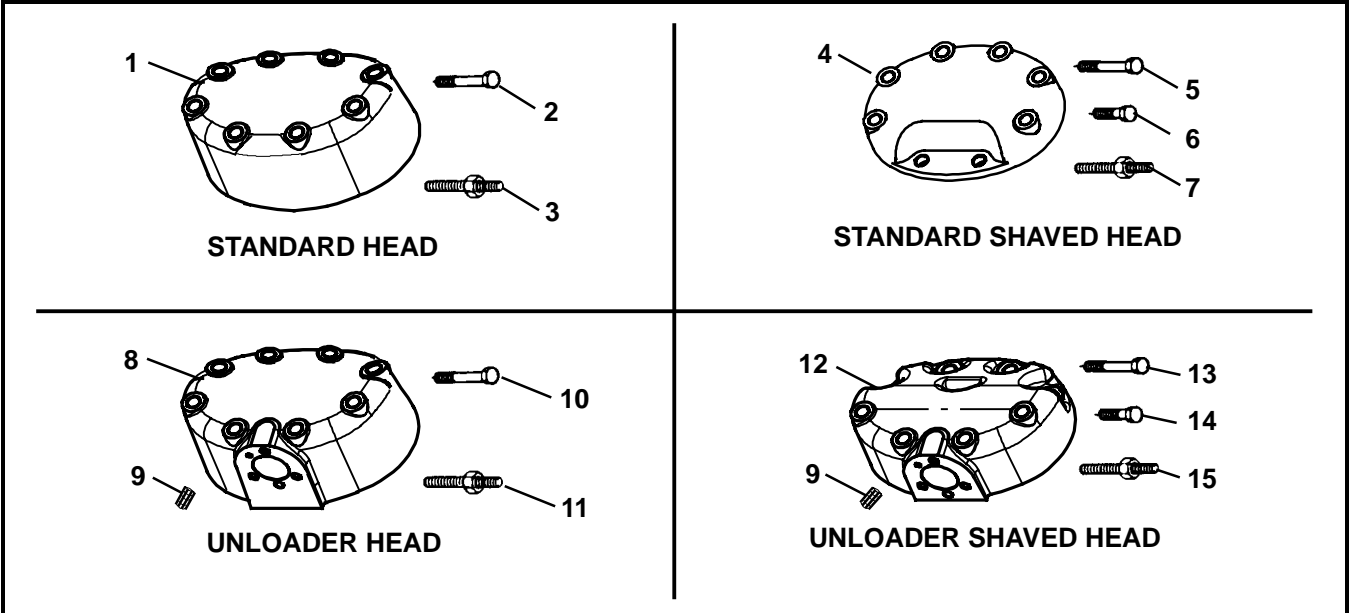

Item	Part Number	Description	Qty
1	17-40015-00	Cylinder Head - Side Bank (No Unloader)	1
2	17-44116-00	Capscrew, Hex Head, 3/8-16 x 2-3/4 Inches Long - SAE Grade 8	8
3	17-44017-01	Stud, Cylinder Head, 3/8-16 x 3-3/4 Inches Long	A/R
4	17-21040-00	Cylinder Head - Side Bank (No Unloader - Shaved)	2
5	17-40034-05	Capscrew, Hex Head, 3/8-16 x 2 Inches Long - SAE Grade 8	6
6	17-40037-05	Stud, Cylinder Head, 3/8-16 x 1 Inch Long	2
7	17-44732-00	Stud, Cylinder Head, 3/8-16 x 2 Inches Long	A/R
8	17-21041-00	Cylinder Head - Side Banks (Unloader - Suction Cutoff)	1
	17-40104-05	Cylinder Head - Side Banks (Unloader - Hot Gas Bypass)	
9	17-40108-00	Strainer	1
10	17-10224-05	Capscrew, Hex Head, 3/8-16 x 3-1/4 Inches Long - SAE Grade 8	8
11	17-44017-03	Stud, Cylinder Head, 3/8-16 x 4-1/4 Inches Long	A/R
12	17-44084-00	Cylinder Head - Side Banks (Unloader - Hot Gas Bypass - Shaved)	A/R
13	17-44117-00	Capscrew, Hex Head, 3/8-16 x 2-1/4 Inches Long - SAE Grade 8	6
14	AA06GR232	Capscrew, Hex Head, 3/8-16 x 1-1/4 Inches Long - SAE Grade 8	2
15	17-44780-00	Stud, Cylinder Head (Shaved), 3/8-16 x 3-1/4 Inches Long	A/R

7.2 Center Cylinder Head

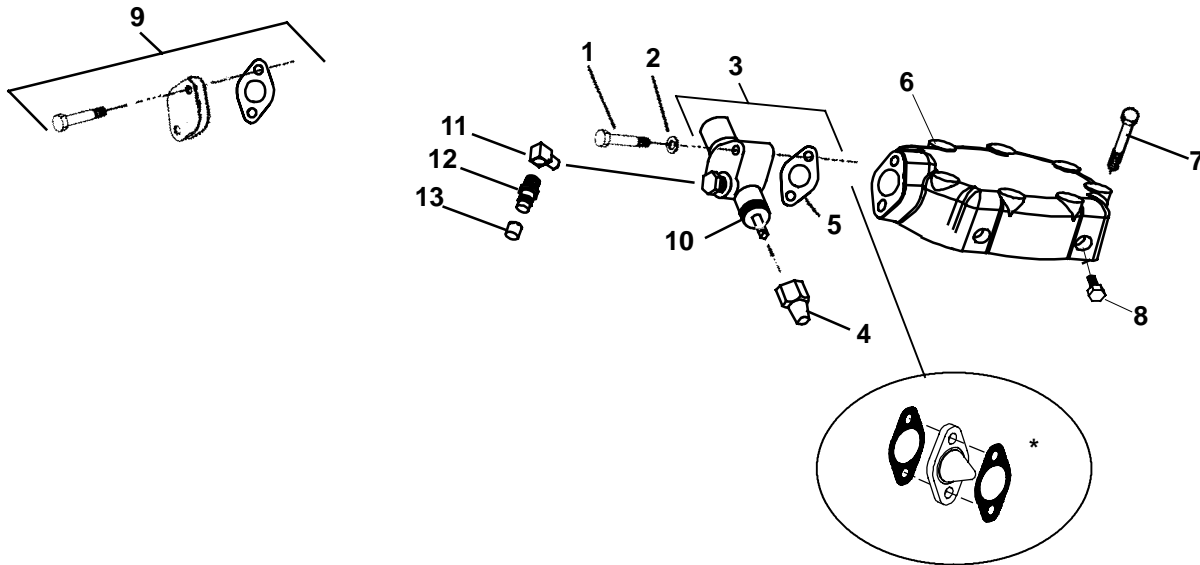

*Note: Discharge Strainer Assembly; See Applicable Unit Parts List

Item	Part Number	Description	Qty
1	34-00302-16	Capscrew, Hex Head, 5/16 -18 x 2 Inches Long - SAE Grade 5	2
2	17-40013-00	Gasket, Capscrew, 5/16 Inch	2
3	14-01042-07	Valve, Service 7/8 Inch ODF (1/8 Inch FPT Gauge Port)- Includes:	1
	14-00206-01	Valve, Service 7/8 Inch ODF (M15 Gauge Port For R-134a) - Includes:	
4	17-10812-01	Cap, Service Valve (Plastic) (With Relief Hole)	1
5	17-10811-05	Gasket, Service Valve (Fiber)	1
	17-44138-00	Gasket, Service Valve (Metal)	
4	17-10806-10	Cap, Service Valve (Brass)	1
6	17-44752-00	Cylinder Head, Center Bank, One Pressure Port (Bus)	1
	17-44754-00	Cylinder Head, Center Bank, Two Pressure Ports (T/T)	
7	17-10224-05	Capscrew, Hex Head, 3/8 -16 x 3 -1/4 Inches Long - SAE Grade 8	8
8	CA63AA051	Pipe Plug, 1/4 -18NPT (package of 20)	A/R
9	17-13004-00	Kit, Valve Pad Blank Off, 2 Bolt Service Valve	1
10	17-13022-00	Graphite Packing, Service Valve Stem (2-Bolt)	1
11	40-00524-01	Elbow, 1/8 MPT x M15 - Brass (for R -134a)	1
12	40-00520-01	Coupling, M15, High Side - Brass - Includes:	1
13	40-00520-03	Cap, Service Port	1
11	40-00060-08	Elbow, 1/8 MPT x 1/4 FPT - Brass (for R -12, R -22)	1
12	06DA403-844	Valve, Access (1/4 Flare, Schrader)	1
13	DD19CA061	Cap, 1/4 Flare, Schrader	1

8. VALVE PLATE ASSEMBLY

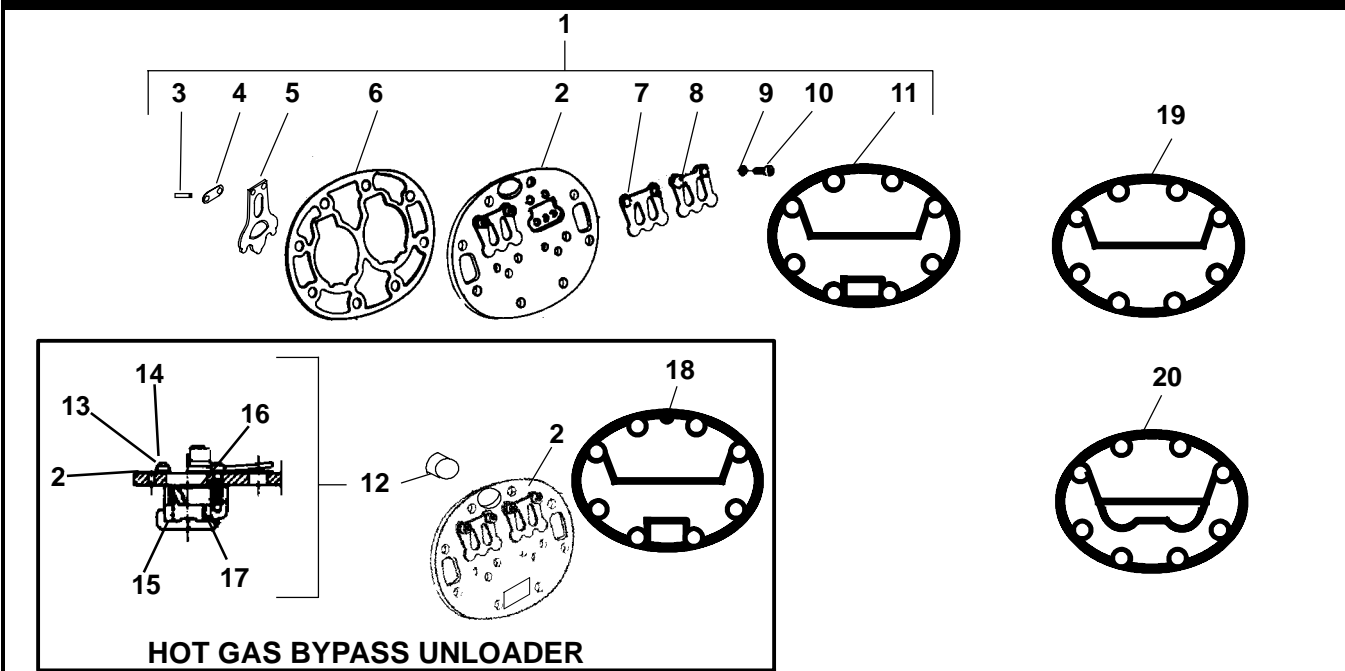

Item	Part Number	Description	Qty
1	17-44104-00	Valve Plate, Canted, Side Bank W/ Hot Gas Bypass Unloader (Truck) - Includes:	1
	17-44105-00	Valve Plate, Canted, Center Or Side Bank With Suction Cutoff Unloader Or No Unloader (Truck) - Includes:	
	17-44106-00	Valve Plate, Flat, Side Bank With Hot Gas Bypass Unloader (Bus) - Includes:	
	17-44107-00	Valve Plate, Flat, Center And Side With Suction Cutoff Unloader (Bus) - Includes:	
2	NSS	Valve Plate	1
3	17-40057-00	Dowel, Pin Suction Valve	4
4	17-40083-00	Spring, Suction Valve Position	2
5	17-44111-00	Valve, Suction (0.018 Inch Thick) - O5G and O5K	2
6	17-44007-06	Gasket, Valve Plate, O5G	1
	17-55002-00	Gasket, Valve Plate, O5K	
7	17-40086-00	Valve, Discharge	2
8	17-44160-00	Stop, Discharge Valve	2
9	17-10715-00	Lockwasher, 1/4	4
10	17-44113-00	Capscrew, HexHead, 1/4-28 x 3/8 Inch Long	4
11	17-44123-00	Gasket, Center Cylinder Head	1
12	17-55012-00	Unloader Check Valve (Hot Gas Bypass Unloader) - Includes:	1
13	NSS	Lockwasher, #6	2
14	NSS	Screw, Round Phillips Head, #6-32 x 1/2 Inch Long	2
15	NSS	Body Check Valve	1
16	17-40104-08	Piston, Check Valve	1
17	17-40104-09	Spring, Check Valve	1
18	17-44126-00	Gasket, Side Cylinder Head (Hot Gas Bypass Unloader)	1
19	17-44124-00	Gasket, Side Cylinder Head (No Unloader)	1
20	17-44125-00	Gasket, Side Cylinder Head (Suction Cutoff Unloader)	1

9. UNLOADERS

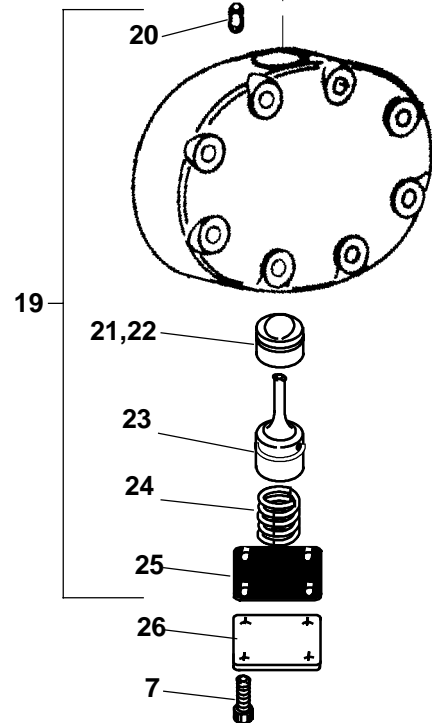
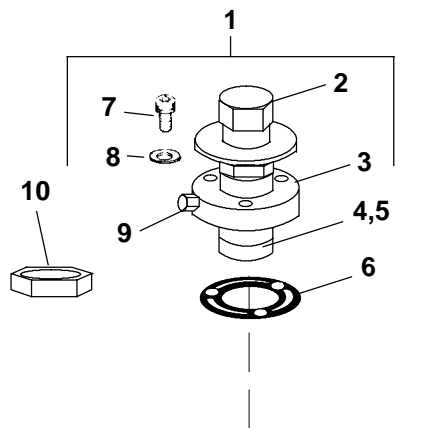
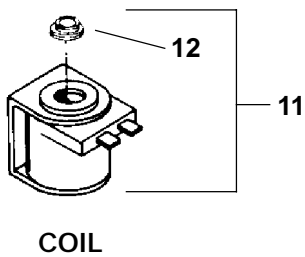
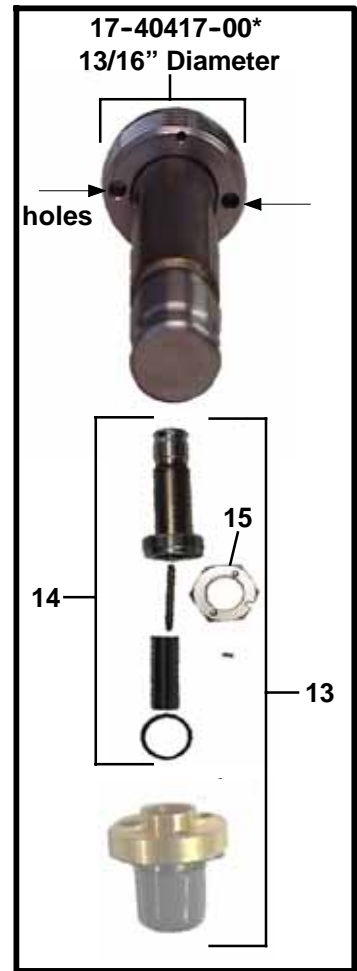

* **NOTE:** If Unloader 17-40415-00 needs stem repair, Unloader 17-40417-00 is to be substituted, entirely. 17-40417-00 Replaces all previous unloaders.

9. UNLOADERS (Continued)			
Item	Part Number	Description	Qty
1	17-55018-01	Valve Assembly (Pressure) - Includes:	A/R
2	NSS	Power Assembly, Unloader (Suction Pressure Activated)	1
3	NSS	Body Assembly, Valve	1
4	17-40409-00	Piston (For Hot Gas Bypass Unloaders) - Includes:	1
5	17-55010-00	Ring, Piston	1
6	17-40104-07	Gasket, Unloader Valve	1
7	17-40111-00	Screw, Socket Head, 1/4-28 x 3/4 Inch Long	1
8	17-40104-20	Gasket, Socket Head Screw, 1/4 Inch	1
9	14-50100-00	Cap, Adjustment Screw With O-Ring	1
10	34-01139-00	Nut, Unloader Adjuster Lock	1
11	22-02567-00	Coil, Valve, 12 VDC with Spade Terminal - Includes:	A/R
	14-00143-07	Coil, Valve, 12 VDC with 6 inch wire leads - Includes:	
	22-50030-00	Coil, Valve, 24 VDC with 42 inch wire leads - Includes:	
	22-02567-01	Coil, Valve, 24 VAC with Spade Terminal - Includes:	
	16-00149-00	Coil, Valve, 115 VAC with 42 inch wire leads - Includes:	
	17-10829-00	Coil, Valve, 230 VAC with 42 inch wire leads - Includes:	
12	17-40408-02	Cap, Snap	1
13	17-40417-00	Valve Assembly (Electric) - Includes:	A/R
3	NSS	Body Assembly, Valve	1
4	17-40409-00	Piston (For Hot Gas Bypass Unloaders) - Includes:	1
5	17-55010-00	Ring, Piston	1
6	17-40104-07	Gasket, Unloader Valve	1
7	17-40111-00	Screw, Socket Head, 1/4-28 x 3/4 Inch Long	1
8	17-40104-20	Gasket, Socket Head Screw, 1/4 Inch	1
14	17-40418-00	Kit, Valve Stem Repair (For 17-40417-00) - Includes:	1
15	NSS	Tool, Installation Remover (13/16 Inch Nut)	1
16	16-00143-01	Kit, Valve Stem Repair (For 17-40407-20- NLO) - Includes:	1
17	NSS	Tool, Installation Remover (1 Inch Nut)	1
18	17-55022-00	O-Ring	1
19	17-21055-00	Kit, Repair (For Suction Cutoff Unloaders) - Includes:	2
20	17-40108-00	Strainer	1
21	17-21047-00	Ring, Piston	1
22	NSS	Piston	1
23	NSS	Body, Valve	1
24	17-21044-00	Spring, Compression	1
25	17-21046-00	Gasket, Valve Cover	1
26	17-21045-00	Cover, Valve	1
7	17-40111-00	Screw, Socket Head, 1/4-28 x 3/4 Inch Long	4

NOTE: 17-40407-20 and 17-40415-00 Unloader Assemblies are no longer offered, use Item 13.

9. UNLOADERS (Continued)

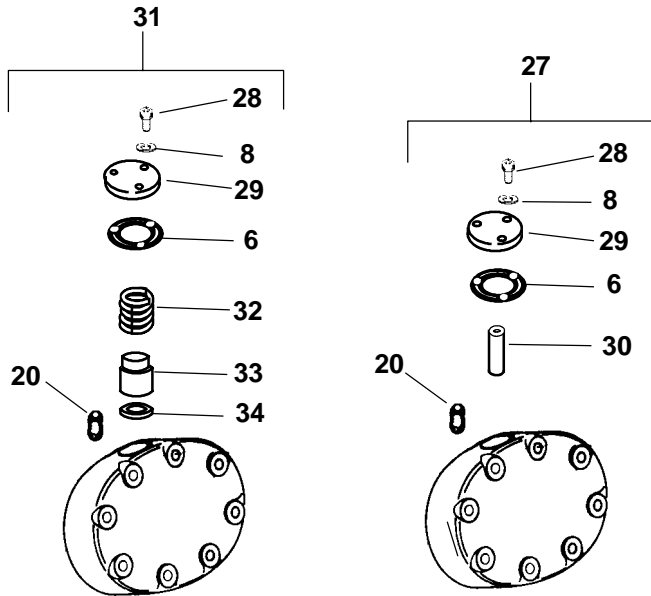

PLUG -- HOT GAS BYPASS

PLUG -- SUCTION CUTOFF

Item	Part Number	Description	Qty
27	17-21056-00	Kit, Plug (Suction Cutoff To Fully Loaded) - Includes:	A/R
28	17-10721-00	Screw, Socket Head, 1/4-28 x 1 Inch Long	3
29	NSS	Plate, Cover	1
30	NSS	Sleeve, Plug	1
6	17-40104-07	Gasket, Unloader Valve	1
8	17-40104-20	Gasket, Socket Head Screw, 1/4 Inch	1
31	17-55013-00	Kit, Plug (Hot Gas Bypass To Fully Loaded) - Includes:	A/R
32	NSS	Spring	1
33	NSS	Plug	1
34	17-55014-00	Ring, Seat	1
6	17-40104-07	Gasket, Unloader Valve	1
8	17-40104-20	Gasket, Socket Head Screw, 1/4 Inch	1
20	17-40108-00	Stainer	1
28	17-10721-00	Screw, Socket Head, 1/4-28 x 1 Inch Long	3
29	NSS	Plate, Cover	1

10. UNLOADER KITS, BUS

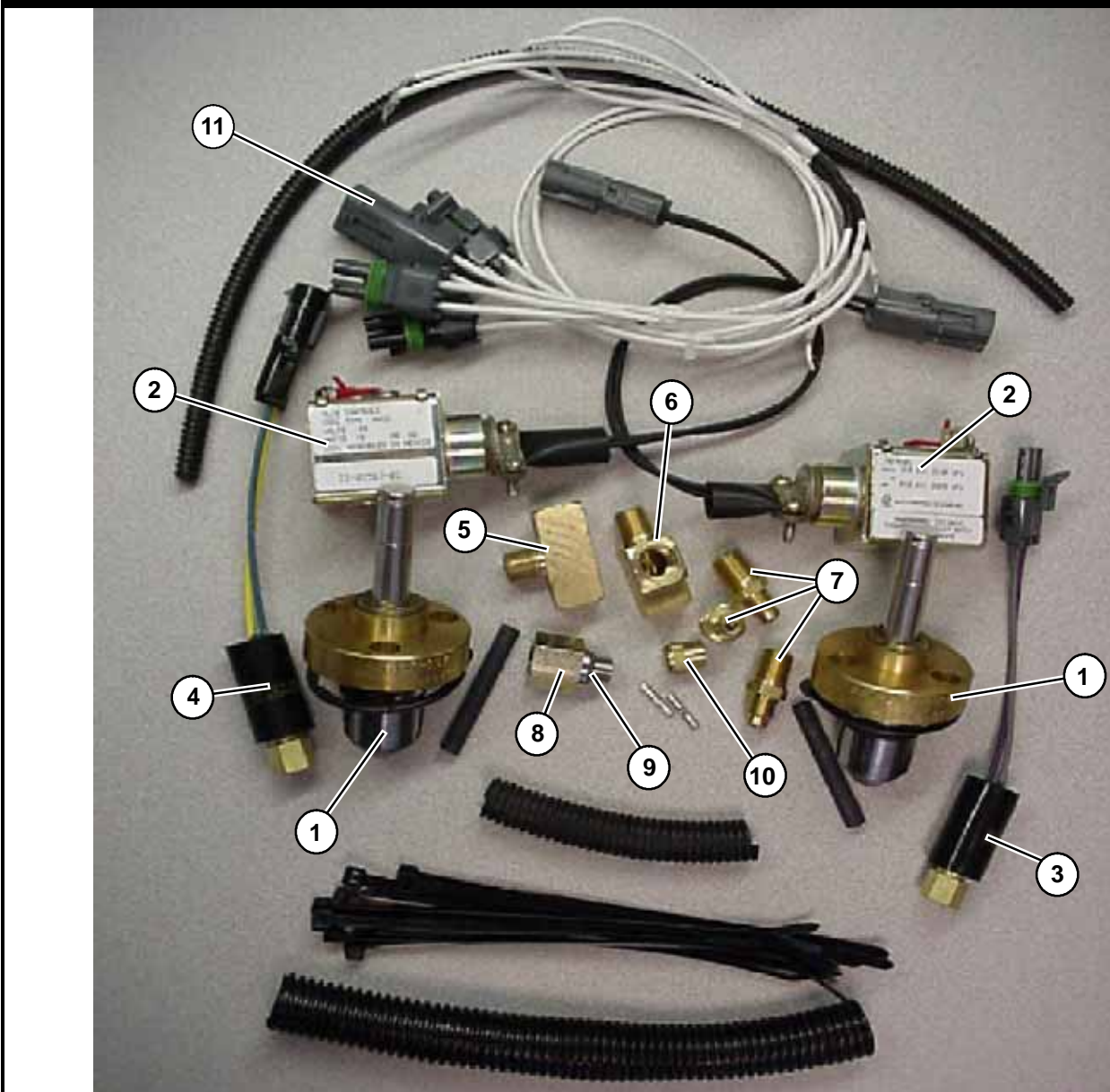

10.1 Pressure To Electric Unloader Kit - R-134a ONLY - 24 VDC			
Item	Part Number	Description	Qty
	74-50111-00	Kit, Convert Pressure Hot Gas Bypass to Electric Unloader (24 VDC), Includes:	2
1	17-40417-00	Unloader Valve	2
2	68PD-2-102-3	Solenoid Coil - 24 VDC	2
3	12-00334-02	Switch, Pressure (UPS2) - R-134a	1
4	12-00334-03	Switch, Pressure (UPS1) - R-134a	1
5	40-00249-01	Fitting, Tee, Male Branch, 1/4 FPT x 1/4 FPT x 1/4 MPT	1
6	40-00243-01	Fitting, Tee, Street, 1/4 MPT x 1/4 x 1/4 FPT	1
7	06DA403-844	Valve, Access (1/4 Flare, Schrader)	3
8	40-00528-02	Connector, 1/4 FPT x 7/16-20 Straight Thread With O-Ring - Includes:	1
9	42-00243-07	O-Ring	1
10	DD19CA061	Cap, 1/4 Flare, Schrader	1
11	22-50222-00	Wire Harness	1

10.2 Pressure To Electric Unloader Kit - R-22 ONLY - 24 VDC

Item	Part Number	Description	Qty
	74-50111-01	Kit, Convert Pressure Hot Gas Bypass to Electric Unloader (24 VDC), Includes:	2
1	17-40417-00	Unloader Valve	2
2	68PD-2-102-3	Solenoid Coil - 24 VDC	2
3	12-00334-00	Switch, Pressure (UPS2) - R-22	1
4	12-00334-01	Switch, Pressure (UPS1) - R-22	1
5	40-00249-01	Fitting, Tee, Male Branch, 1/4 FPT x 1/4 FPT x 1/4 MPT	1
6	40-00243-01	Fitting, Tee, Street, 1/4 MPT x 1/4 x 1/4 FPT	1
7	06DA403-844	Valve, Access (1/4 Flare, Schrader)	3
8	40-00528-02	Connector, 1/4 FPT x 7/16-20 Straight Thread With O-Ring - Includes:	1
9	42-00243-07	O-Ring	1
10	DD19CA061	Cap, 1/4 Flare, Schrader	1
11	22-50222-00	Wire Harness	1

10.3 Pressure To Electric Unloader Kit - R-134a ONLY - 36 VDC

	74-50111-02	Kit, Convert Pressure Hot Gas Bypass to Electric Unloader (36 VDC), Includes:	2
1	17-40417-00	Unloader Valve	2
2	14-50086-00	Solenoid Coil - 36 VDC	2
3	12-00334-02	Switch, Pressure (UPS2) - R-134a	1
4	12-00334-03	Switch, Pressure (UPS1) - R-134a	1
5	40-00249-01	Fitting, Tee, Male Branch, 1/4 FPT x 1/4 FPT x 1/4 MPT	1
6	40-00243-01	Fitting, Tee, Street, 1/4 MPT x 1/4 x 1/4 FPT	1
7	06DA403-844	Valve, Access (1/4 Flare, Schrader)	3
8	40-00528-02	Connector, 1/4 FPT x 7/16-20 Straight Thread With O-Ring - Includes:	1
9	42-00243-07	O-Ring	1
10	DD19CA061	Cap, 1/4 Flare, Schrader	1
11	22-50222-00	Wire Harness	1

10.4 Pressure To Electric Unloader Kit - R-22 ONLY - 36 VDC

	74-50111-03	Kit, Convert Pressure Hot Gas Bypass to Electric Unloader (36 VDC), Includes:	2
1	17-40417-02	Unloader Valve	2
2	14-50086-00	Solenoid Coil - 36 VDC	2
3	12-00334-00	Switch, Pressure (UPS2) - R-22	1
4	12-00334-01	Switch, Pressure (UPS1) - R-22	1
5	40-00249-01	Fitting, Tee, Male Branch, 1/4 FPT x 1/4 FPT x 1/4 MPT	1
6	40-00243-01	Fitting, Tee, Street, 1/4 MPT x 1/4 x 1/4 FPT	1
7	06DA403-844	Valve, Access (1/4 Flare, Schrader)	3
8	40-00528-02	Connector, 1/4 FPT x 7/16-20 Straight Thread With O-Ring - Includes:	1
9	42-00243-07	O-Ring	1
10	DD19CA061	Cap, 1/4 Flare, Schrader	1
11	22-50222-00	Wire Harness	1

11. GASKET SETS

11.1 Fiber Universal Gasket Set

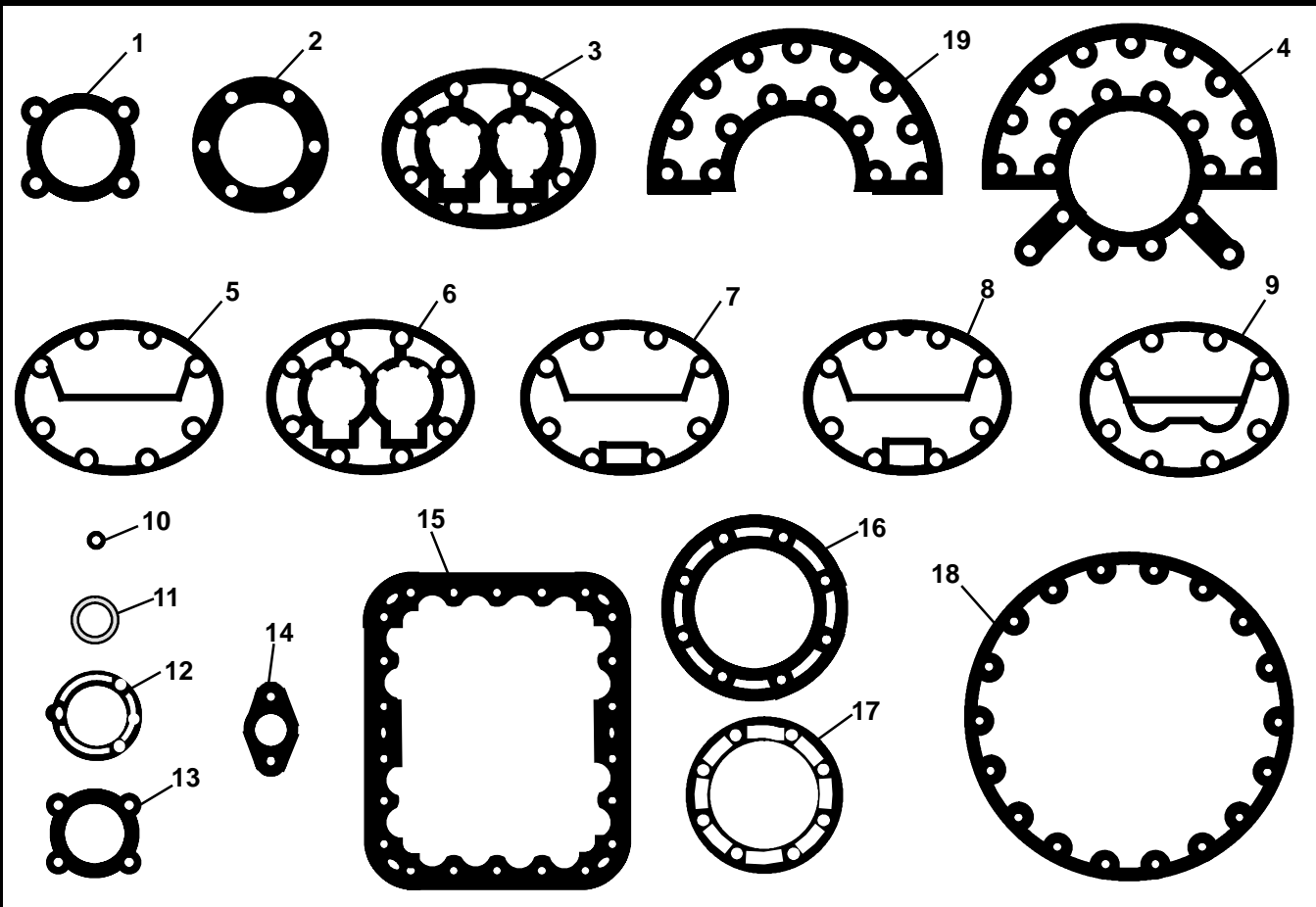

Item	Part Number	Description	Qty
-	17-55020-20	Gasket Set, Universal, Fiber - Includes:	1
1	17-40005-05	Gasket, Suction Service Valve - 4 Bolt	1
2	17-44004-06	Gasket, Shaft Seal, O5G with Standard Cover Plate - Steel	1
3	17-44007-06	Gasket, Valve Plate, O5G	3
4	17-44119-00	Gasket, End Flange, O5G - Metal - Includes:	1
5	17-44124-00	Gasket, Cylinder Head - Side Bank (No Unloader)	2
6	17-55002-00	Gasket, Valve Plate, O5D (Not Used For This Compressor)	3
7	17-44123-00	Gasket, Cylinder Head - Center	1
8	17-44126-00	Gasket, Cylinder Head - Side Bank (Hot Gas Bypass Unloader)	2
9	17-44125-00	Gasket, Cylinder Head - Side Bank (Suction Cutoff Unloader)	2
10	17-40316-00	Gasket, Oil Supply Tube, O5D (Not Used For This Compressor)	1
11	17-44021-00	Gasket, Sight Glass - Metal	2
12	17-40104-07	Gasket, Unloader Body	2
13	17-40075-05	Gasket, Oil Pump Cover	1
14	17-10811-05	Gasket, Service Valve (2 Bolt) - 1-3/4 Inch Center	2
15	17-40033-05	Gasket, Bottom Plate	1
16	17-44022-00	Gasket, Pump End Bearing Head	1
17	17-40319-05	Gasket, Shaft Seal, O5D (Not Used For This Compressor)	1
18	17-40029-05	Gasket, Motor End Cover, O5D (Not Used For This Compressor)	1
19	17-44118-00	Gasket, End Flange - Metal	1

11.2 Metal Gasket Set

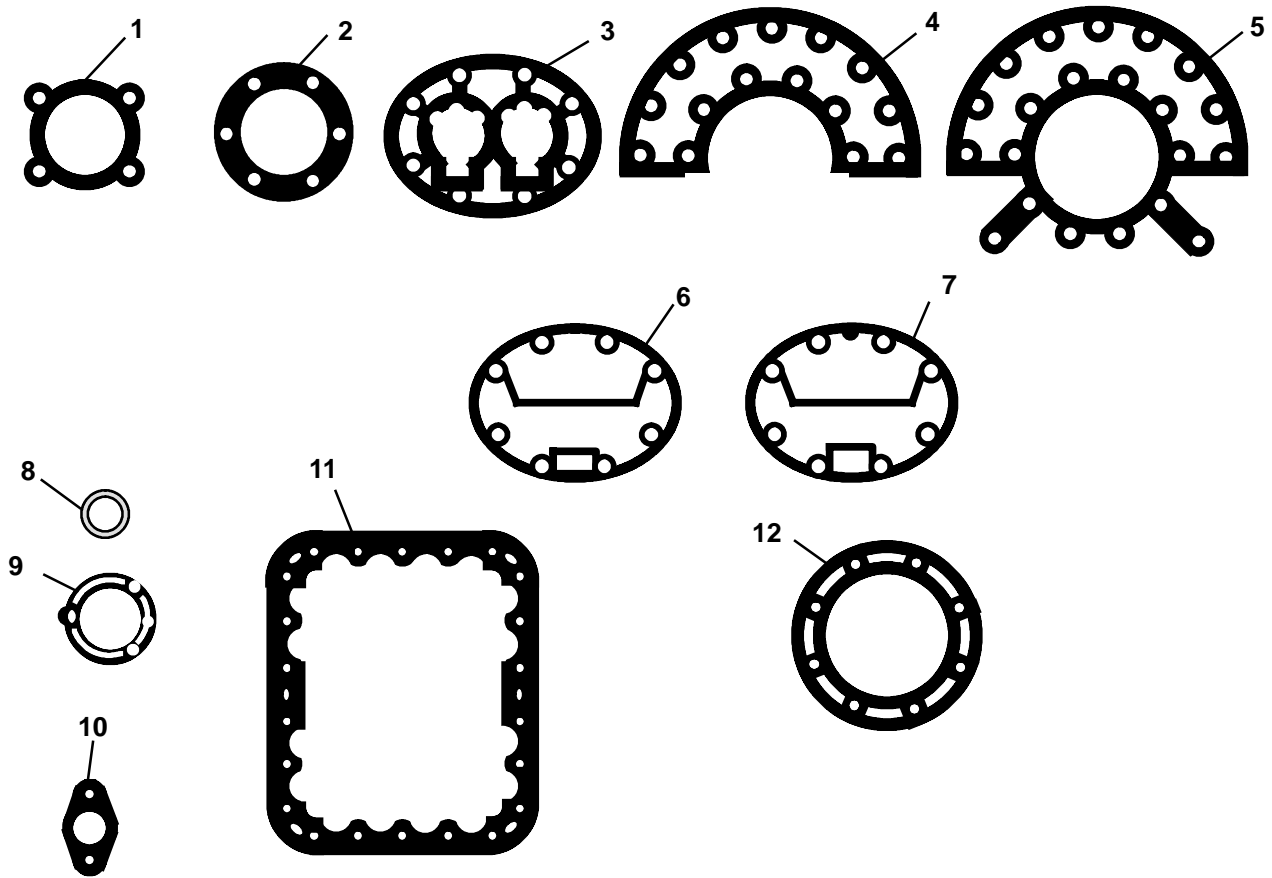

Item	Part Number	Description	Qty
-	17-55026-00	Gasket Set, Metal - Includes:	1
1	17-44141-00	Gasket, Suction Service Valve - 4 Bolt	1
2	17-44004-06	Gasket, Shaft Seal	1
3	17-44007-06	Gasket, Valve Plate	3
4	17-44118-00	Gasket, End Flange	1
5	17-44119-00	Gasket, End Flange	1
6	17-44123-00	Gasket, Cylinder Head - Center	1
7	17-44126-00	Gasket, Cylinder Head - Side Bank (hot Gas Bypass Unloader)	2
8	17-44021-00	Gasket, Sight Glass	2
9	17-40104-07	Gasket, Unloader Body	2
10	17-44138-00	Gasket, Service Valve - 2 Bolt	2
11	17-44129-00	Gasket, Bottom Plate	1
12	17-44022-00	Gasket, Pump End Bearing Head	1

12. CLUTCH ASSEMBLIES

12.1 Shaft Mounted Clutch Assembly

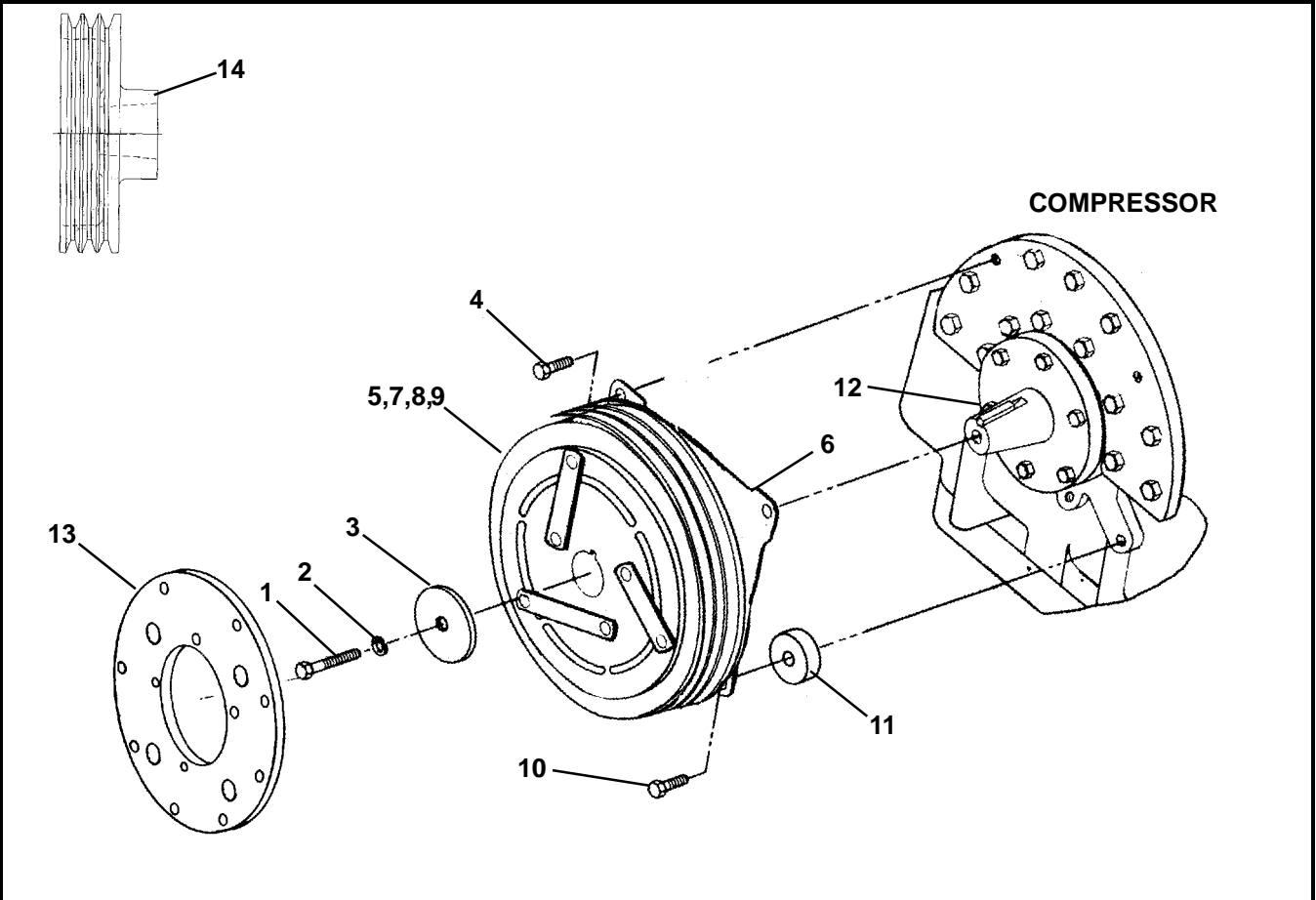

Item	Part Number	Description	Qty
1	34-00613-07	Capscrew, Hex Head, 3/8 UNF x 7/8 Inch Long - SAE Grade 8	1
2	AU11AR241	Washer, Lock, Spring, 3/8 Inch	1
3	34-00616-00	Washer, 13/32 ID x 1-1/2 OD x 3/16 Inch Thick	1
4	17-40037-05	Capscrew, Hex Head, 3/8-16 x 1 Inch Long	2
5	50-01108-00	Clutch, 24 VDC, 2-C Grooves, 9 Inch Diameter	1
	50-01110-00	Clutch, 24 VDC, 3-3V Grooves, 8.48 Inch Diameter	
	50-01110-01	Clutch, 12 VDC, 3-3V Grooves, 8.48 Inch Diameter	
	50-01114-00	Clutch, 12 VDC, 2-B Grooves, 8.64 Inch Diameter	
6	50-50011-00	Coil, 24 VDC	1
	50-50014-00	Coil, 12 VDC	
7	50-50015-00	Ring, Retaining - External	1
8	50-50016-00	Ring, Retaining - Internal	1
9	50-50017-00	Bearing	1
10	17-10308-00	Capscrew, Hex Head, 3/8-16 x 1-1/4 Inches Long - SAE Grade 8	2
11	68G2-8522-1	Spacer, 1-3/8 OD x 1/2 Inch Thick - CRES	2
12	17-40324-00	Key, Crankshaft, 1/4 x 1/4 x 1-1/2 Inches Long	1
13	50-01115-00	Plate, Adapter (Used with 50-01114 Clutch)	1
14	68G2-1823	Sheave, Power Takeoff, 3-3V Grooves, 6 Inch Diameter, (On Allison Transmission)	1

12.2 Housing Mounted (Warner - Gray In Color) Clutch Assembly

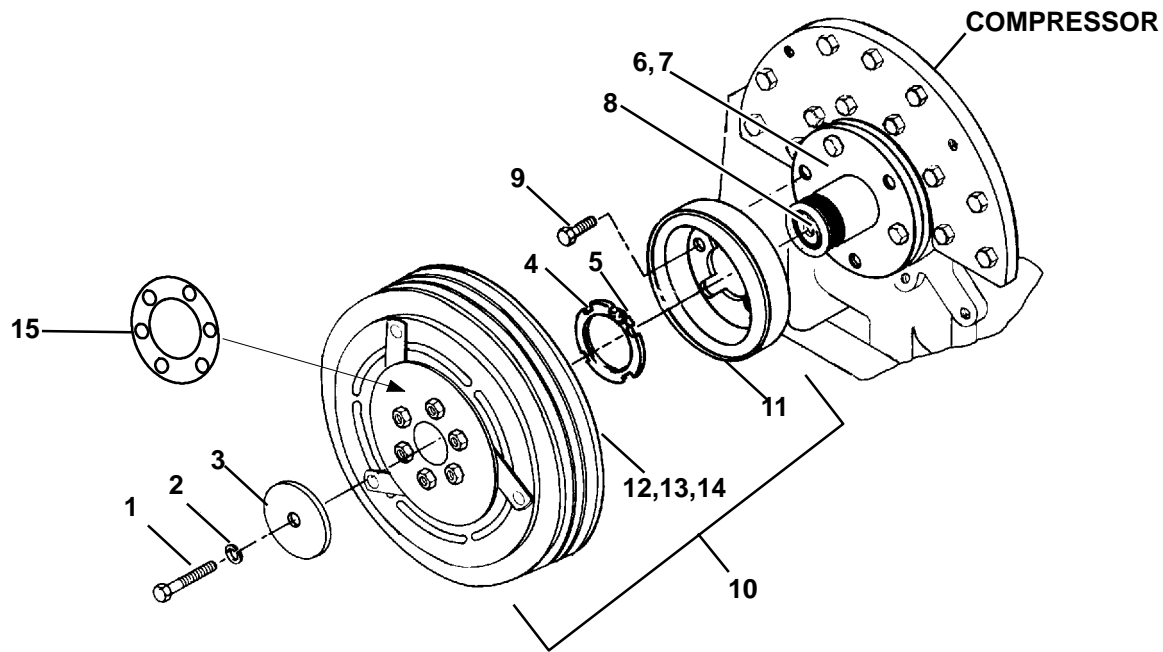

Item	Part Number	Description	Qty
NS	76-50013-00	Kit, Conversion Shaft to Housing Mounted Clutch	A/R
1	34-00613-07	Capscrew, Hex Head, 3/8-24 x 7/8 Inch Long - SAE Grade 8	1
2	AU11AR241	Washer, Lock, Spring, 3/8 Inch	1
3	34-00616-00	Washer, 13/32 ID x 1-1/2 OD x 3/16 Inch Thick	1
4	34-01161-00	Nut, Hub, With Grease Fitting Port (Fitting Not Included)	1
	34-06083-00	Nut, Hub Without Grease Fitting Port	
5	40-01132-00	Fitting, Grease, 1/4-18	1
6	17-44041-01	Hub, Clutch Mounting - Includes:	1
7	17-44042-00	Ring, Felt and Retainer	1
8	68G2-9072	Key, Crankshaft, Special	1
9	17-10308-00	Capscrew, Hex Head, 3/8-16 x 1-1/4 Inches Long - SAE Grade 8	1
10	50-01122-01	Clutch, Assembly, 24 VDC, 2-C Grooves, 9 Inch Diameter - Includes:	1
11	50-01122-50	Coil, 24 VDC	1
12	50-01122-85	Rotor/Armature, 2-C Grooves, 9 Inch Diameter - Includes:	1
13	34-01186-00	Ring, Snap	1
14	04-00130-00	Bearing, Rotor	1
10	50-01122-04	Clutch, Assembly, 12 VDC, 2-C Grooves, 9 Inch Diameter - Includes:	1
11	50-01122-41	Coil, 12 VDC	1
12	50-01122-85	Rotor/Armature, 2-C Grooves, 9 Inch Diameter - Includes:	1
13	34-01186-00	Ring, Snap	1
14	04-00130-00	Bearing, Rotor	1
10	50-01122-02	Clutch, Assembly, 24 VDC, 3-3V Grooves, 8.48 Inch Diameter - Includes:	1
11	50-01122-50	Coil, 24 VDC	1
12	50-01122-86	Rotor/Armature, 3-3V Grooves, 8.48 Inch Diameter - Includes:	1
13	34-01186-00	Ring, Snap	1
14	04-00130-00	Bearing, Rotor	1

12.2 Housing Mounted (Warner - Gray In Color) Clutch Assembly - Continued			
Item	Part Number	Description	Qty
10	50-01122-07	Clutch, Assembly, 24 VDC, 2-B Grooves, 9 Inch Diameter - Includes:	1
11	50-01122-50	Coil, 24 VDC	1
12	50-01122-90	Rotor/Armature, 2-B Grooves, 9 Inch Diameter - Includes:	1
13	34-01186-00	Ring, Snap	1
14	04-00130-00	Bearing, Rotor	1
10	50-01122-09	Clutch, Assembly, 24 VDC, 4 Grooves (2-A/2-B), 10.35 Inch Diameter - Includes:	1
11	50-01122-50	Coil, 24 VDC	1
12	50-01122-501	Rotor/Armature, 4 Grooves (2-A/2-B), 10.35 Inch Diameter - Includes:	1
13	34-01186-00	Ring, Snap	1
14	04-00130-00	Bearing, Rotor	1
10	50-01122-12	Clutch, Assembly, 24 VDC, 2-5V Grooves, 8.7 Inch Diameter - Includes:	1
11	50-01122-50	Coil, 24 VDC	1
12	50-01122-91	Rotor/Armature, 2-5V Grooves, 8.7 Inch Diameter - Includes:	1
13	34-01186-00	Ring, Snap	1
14	04-00130-00	Bearing, Rotor	1
10	50-01122-14	Clutch, Assembly, 24 VDC, 2-5V Grooves, 10.5 Inch Diameter - Includes:	1
11	50-01122-50	Coil, 24 VDC	1
12	50-01122-93	Rotor/Armature, 2-5V Grooves, 10.5 Inch Diameter - Includes:	1
13	34-01186-00	Ring, Snap	1
14	04-00130-00	Bearing, Rotor	1
15	50-01122-65	Shim, .010 Inch Thick	5
	50-01122-66	Shim, .020 Inch Thick	1

12.3 Housing Mounted (Linnig - Gold In Color) Clutch Assembly

Note: Multiple groove rotor/armature designation describes groove location(s) starting at the compressor side and working out. Example: 3 Grooves 2B/1A shown below.

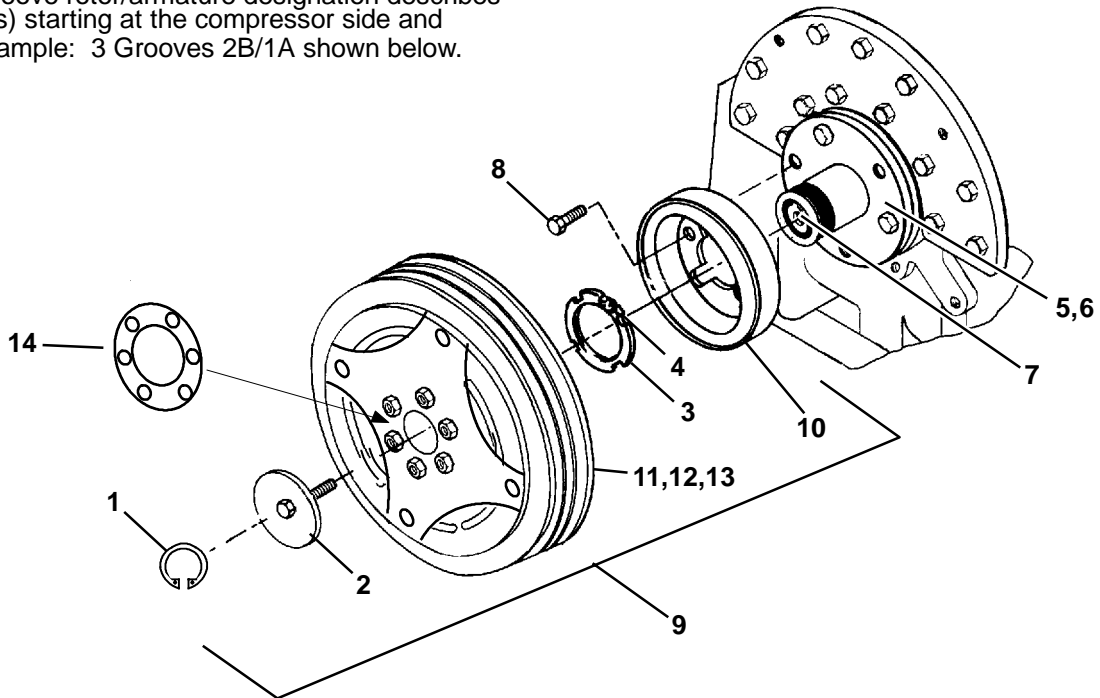

Item	Part Number	Description	Qty
NS	76-50013-00	Kit, Conversion Shaft to Housing Mounted Clutch	A/R
1	34-50035-00	Ring, Snap	1
2	34-50034-00	Bolt, Retaining, Special	1
3	34-01161-00	Nut, Hub, With Grease Fitting Port (Fitting Not Included)	1
	34-06083-00	Nut, Hub Without Grease Fitting Port	
4	40-01132-00	Fitting, Grease, 1/4-18	1
5	17-44041-01	Hub, Clutch Mounting - Includes:	1
6	17-44042-00	Ring, Felt and Retainer	1
7	68G2-9072	Key, Crankshaft, Special	1
8	17-10308-00	Cap screw, Hex Head, 3/8-16 x 1-1/4 Inches Long - SAE Grade 8	1
9	50-00226-09	Clutch Assembly, 24 VDC, 4 Grooves (2A/2B), 10.35 Inch Dia. - Includes:	1
10	50-00226-50	Coil, 24 VDC	1
11	50-00226-501	Rotor/Armature, 4 Grooves (2A/2B), 10.35 Inch Diameter - Includes:	1
12	50-50040-05	Ring, Snap	1
13	50-50040-04	Bearing	1
9	50-00226-18	Clutch Assembly, 12 VDC, 4 Grooves (2B/2A), 10.35 Inch Dia. - Includes:	1
10	50-00226-41	Coil, 12 VDC	1
11	50-50040-11	Rotor/Armature, 4 Grooves (2B/2A), 10.35 Inch Diameter - Includes:	1
12	50-50040-05	Ring, Snap	1
13	50-50040-04	Bearing	1

12.3 Housing Mounted (Linnig - Gold In Color) Clutch Assembly - Continued			
Item	Part Number	Description	Qty
9	50-00226-19	Clutch Assembly, 24 VDC, 4 Grooves (2B/2A), 10.35 Inch Dia. - Includes:	1
10	50-00226-50	Coil, 24 VDC	1
11	50-50040-11	Rotor/Armature, 4 Grooves (2B/2A), 10.35 Inch Diameter - Includes:	1
12	50-50040-05	Ring, Snap	1
13	50-50040-04	Bearing	1
9	50-01130-03	Clutch Assembly, 24 VDC, 3-3V Grooves, 8.48 Inch Diameter - Includes:	1
10	50-00226-50	Coil, 24 VDC	1
11	50-50040-02	Rotor/Armature, 3-3V Grooves, 8.48 Inch Diameter - Includes:	1
12	50-50040-05	Ring, Snap	1
13	50-50040-04	Bearing	1
9	50-01130-20	Clutch Assembly, 12 VDC, 2-B Grooves, 10.35 Inch Diameter - Includes:	1
10	50-00226-41	Coil, 12 VDC	1
11	50-50040-03	Rotor/Armature, 2-B Grooves, 10.35 Inch Diameter - Includes:	1
12	50-50040-05	Ring, Snap	1
13	50-50040-04	Bearing	1
9	50-01130-21	Clutch Assembly, 24 VDC, 2-B Grooves, 10.35 Inch Diameter - Includes:	1
10	50-00226-50	Coil, 24 VDC	1
11	50-50040-03	Rotor/Armature, 2-B Grooves, 10.35 Inch Diameter - Includes:	1
12	50-50040-05	Ring, Snap	1
13	50-50040-04	Bearing	1
9	50-01130-22	Clutch Assembly, 12 VDC, 2-C Grooves, 10 Inch Diameter - Includes:	1
10	50-00226-41	Coil, 12 VDC	1
11	50-50040-12	Rotor/Armature, 2-C Grooves, 10 Inch Diameter - Includes:	1
12	50-50040-05	Ring, Snap	1
13	50-50040-04	Bearing	1
14	50-00226-65	Shim, .012 Inch Thick	5
	50-00226-66	Shim, .039 Inch Thick	1

PART NUMBER INDEX

PART NO.	PAGE NO.	PART NO.	PAGE NO.	PART NO.	PAGE NO.
04-00130-00	18, 19	17-40005-05	1, 15	17-44005-00	1
06DA403-844	1, 8, 13, 14	17-40007-00	1	17-44007-06	15, 16
12-00334-00	14	17-40015-00	7	17-44008-00	4
12-00334-01	14	17-40019-00	6	17-44011-00	2
12-00334-02	13, 14	17-40020-00	2	17-44013-00	8
12-00334-03	13, 14	17-40021-00	2	17-44014-00	6
14-00143-07	11	17-40029-05	15	17-44015-00	1
14-00206-01	8	17-40033-05	15	17-44016-05	4
14-01042-07	8	17-40034-05	7	17-44016-07	4
14-50086-00	14	17-40037-05	7, 17	17-44017-01	7
14-50100-00	11	17-40042-00	2	17-44017-03	7
16-00143-01	11	17-40053-00	4	17-44019-01	5
16-00149-00	11	17-40054-00	4	17-44021-00	15
17-10218-00	1	17-40055-00	4	17-44022-00	3, 15, 16
17-10218-02	1	17-40056-02	4	17-44025-00	6
17-10224-05	7, 8	17-40057-00	4, 9	17-44026-00	2
17-10308-00	3, 17, 18, 20	17-40075-05	15	17-44033-01	3
17-10715-00	9	17-40078-05	3	17-44033-02	3
17-10721-00	12	17-40083-00	9	17-44035-00	2
17-10806-10	1, 8	17-40086-00	9	17-44036-00	4
17-10811-05	8, 15	17-40104-05	7	17-44037-00	1, 2, 3
17-10812-01	1, 8	17-40104-07	11, 12, 15, 16	17-44041-01	5, 18, 20
17-10829-00	11	17-40104-08	9	17-44042-00	5, 18, 20
17-13004-00	8	17-40104-09	9	17-44043-02	5
17-13006-00	1	17-40104-20	11, 12	17-44045-01	4
17-13020-00	1	17-40108-00	7, 11, 12	17-44045-03	4
17-13022-00	8	17-40111-00	11	17-44062-00	17, 18
17-21040-00	7	17-40204-00	3	17-44074-00	4
17-21041-00	7	17-40317-00	4	17-44075-00	4
17-21044-00	11	17-40319-05	15	17-44084-00	7
17-21045-00	11	17-40324-00	4, 17	17-44104-00	9
17-21046-00	11	17-40408-02	11	17-44105-00	9
17-21047-00	11	17-40409-00	11	17-44106-00	9
17-21055-00	11	17-40417-00	11, 13, 14	17-44107-00	9
17-21056-00	12	17-40417-02	14	17-44111-00	9
17-31062-00	1	17-40418-00	11	17-44113-00	9
17-40002-01	1	17-44002-00	6	17-44115-01	4
		17-44004-06	5, 15, 16	17-44115-20	4
				17-44116-00	7
				17-44117-00	2, 7

PART NUMBER INDEX

PART NO.	PAGE NO.	PART NO.	PAGE NO.	PART NO.	PAGE NO.
17-44118-00	6, 15, 16	34-00300-07	4	50-01116-00	17
17-44119-00	6, 15, 16	34-00302-16	8	50-01117-00	17
17-44121-00	16	34-00613-07	4	50-01122-01	18
17-44121-01	4	34-00616-00	4, 17, 18	50-01122-02	18
17-44122-01	4	34-01139-00	11	50-01122-04	18
17-44123-00	9, 15, 16	34-01161-00	5, 18, 20	50-01122-07	19
17-44124-00	9, 15	34-01186-00	18, 19	50-01122-09	19
17-44125-00	9, 15	34-06083-00	5	50-01122-12	19
17-44126-00	9, 15, 16	34-50022-00	1	50-01122-14	19
17-44127-00	6	34-50034-00	20	50-01122-41	18
17-44129-00	2, 16	34-50035-00	20	50-01122-50	18, 19
17-44137-00	3	40-00060-08	8	50-01122-501	19
17-44138-00	8, 16	40-00243-01	13, 14	50-01122-65	19
17-44139-00	3	40-00249-01	13, 14	50-01122-66	19
17-44141-00	1, 16	40-00520-00	1	50-01122-85	18
17-44145-00	5	40-00520-01	8	50-01122-86	18
17-44160-00	9	40-00520-02	1	50-01122-90	19
17-44732-00	7	40-00520-03	8	50-01122-91	19
17-44752-00	8	40-00524-00	1	50-01122-93	19
17-44754-00	8	40-00524-01	8	50-01130-03	21
17-44765-00	5	40-00528-02	13, 14	50-01130-20	21
17-44770-00	5	40-01132-00	5	50-01130-21	21
17-44780-00	7	42-00045-01	3	50-01130-22	21
17-55002-00	9, 15	42-00243-07	1, 2, 3, 13, 14	50-50040-02	21
17-55008-00	4			50-50040-03	21
17-55009-01	3, 4	50-00221-30	5	50-50040-04	20, 21
17-55010-00	11	50-00226-09	20	50-50040-05	20, 21
17-55012-00	9	50-00226-18	20	50-50040-11	20, 21
17-55013-00	12	50-00226-19	21	50-50040-12	21
17-55014-00	12	50-00226-41	20, 21	68G2-1823	17
17-55018-01	11	50-00226-50	20, 21	68G2-8522-1	17
17-55020-20	15	50-00226-501	20	68G2-9072	4, 18, 20
17-55022-00	11	50-00226-65	21	68PD-2-102-3	13, 14
17-55023-00	4	50-00226-66	21	74-50111-00	13
17-55025-00	4	50-01108-00	17	74-50111-01	14
17-55026-00	16	50-01110-00	17	74-50111-02	14
22-02567-00	11	50-01110-01	17	74-50111-03	14
22-50030-00	11	50-01114-00	17	76-50013-00	18, 20
22-50222-00	13, 14	50-01115-00	17	AA06BR293	1
				AA06GR232	7

PART NUMBER INDEX

PART NO.	PAGE NO.
AF55CQ164	4
AU11AR241	17, 18
CA63AA051	1, 2, 8
DD19CA061	1, 8, 13, 14

Carrier Transport Air Conditioning
50 Grumbacher Road
York PA 17406 USA
Tel: 1-800-673-2431
Fax: 1-717-764-0401

North America
Carrier Transicold
700 Olympic Drive
Athens, GA 30601 USA
Tel: 1-706-357-7223
Fax: 1-706-355-5435

**Central America
and Mexico**
Ejercito Nacional No. 418
Piso 9, Torre Yumal
Col. Chapultepec Morales
11570 Mexico, D.F.
Tel: (5255) 9126.0300
Fax: (5255) 9126.0373



Carrier

A United Technologies Company

Carrier Transicold Division,
Carrier Corporation
Truck/Trailer Products Group
P.O. Box 4805
Syracuse, N.Y. 13221 U.S.A

www.carrier.transicold.com



A member of the United Technologies Corporation family. Stock symbol UTX
©2009 Carrier Corporation D Printed in U. S. A. 11/09