

400-230V/3~/50-60Hz

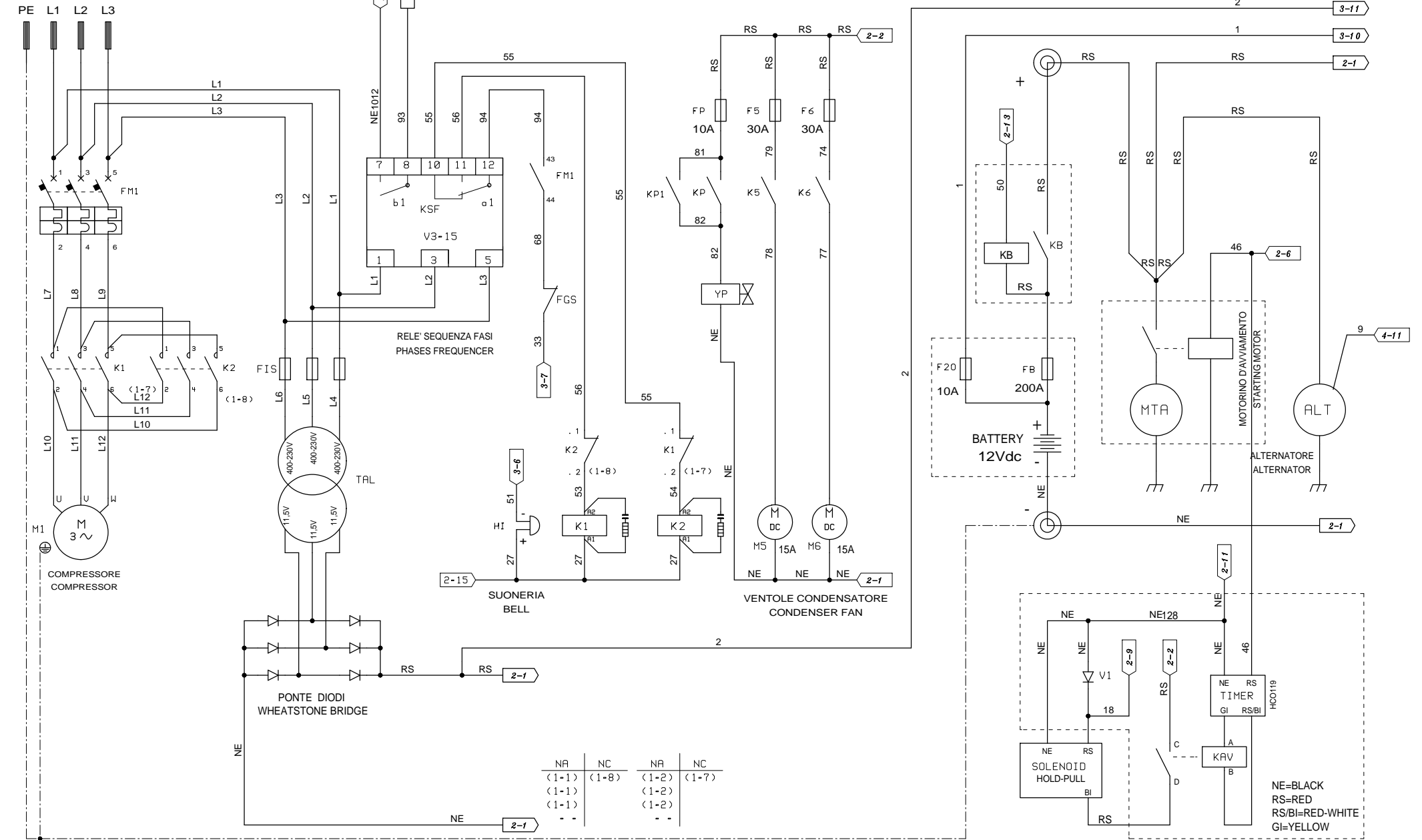

NA	NC	NA	NC
(1-1)	(1-8)	(1-2)	(1-7)
(1-1)		(1-2)	
(1-1)		(1-2)	
..		..	

# SCHEDA DI POTENZA

## POWER BOARD

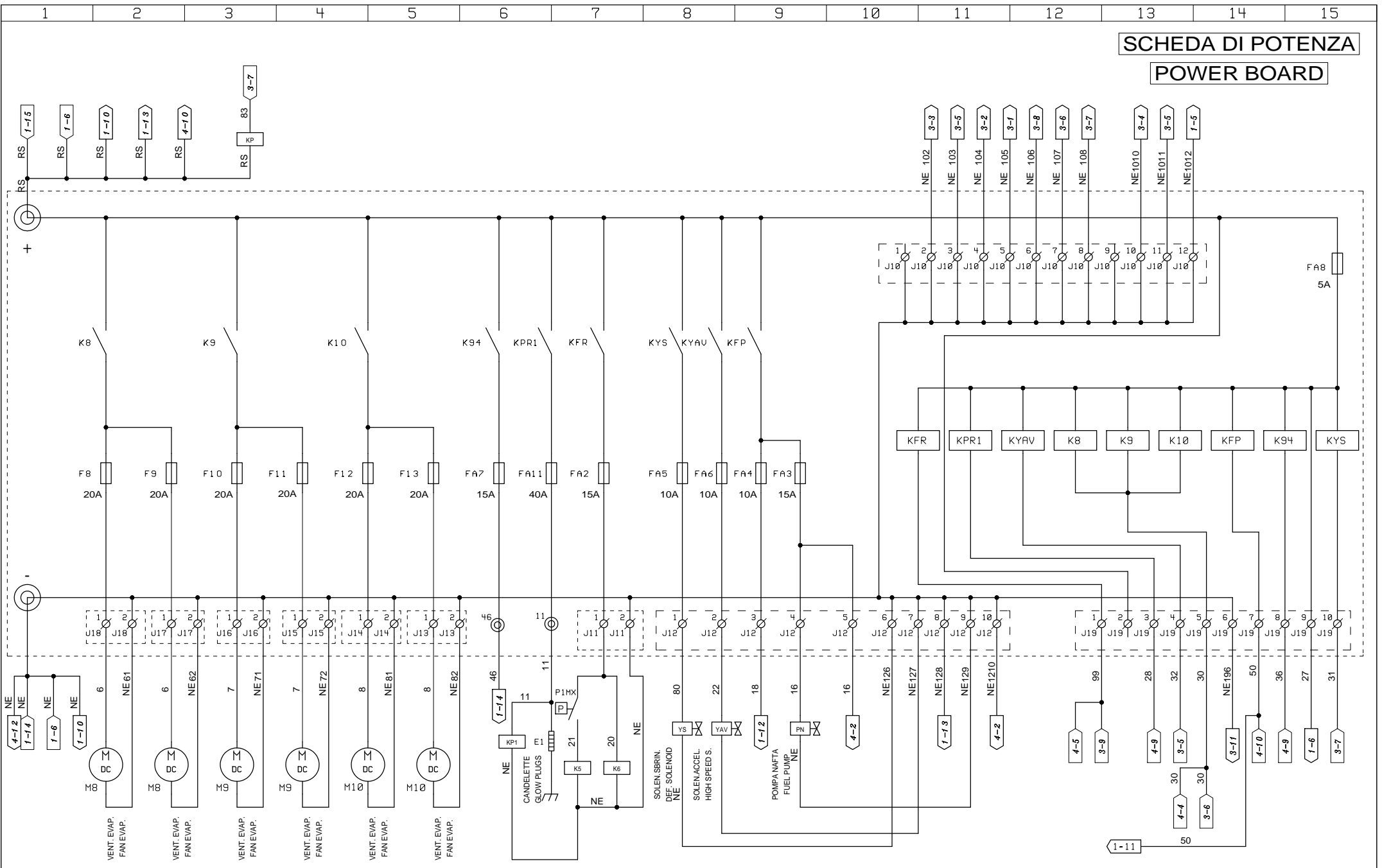

	MODELLO <b>UNO120T...</b>	REV.nr. _____	DISEGNO nr. <b>WDB016</b>	FOGLIO nr. <b>2 DI 5</b>
	DATA: _____	Approvato _____	Disegnato Soncini	Approvato Soncini

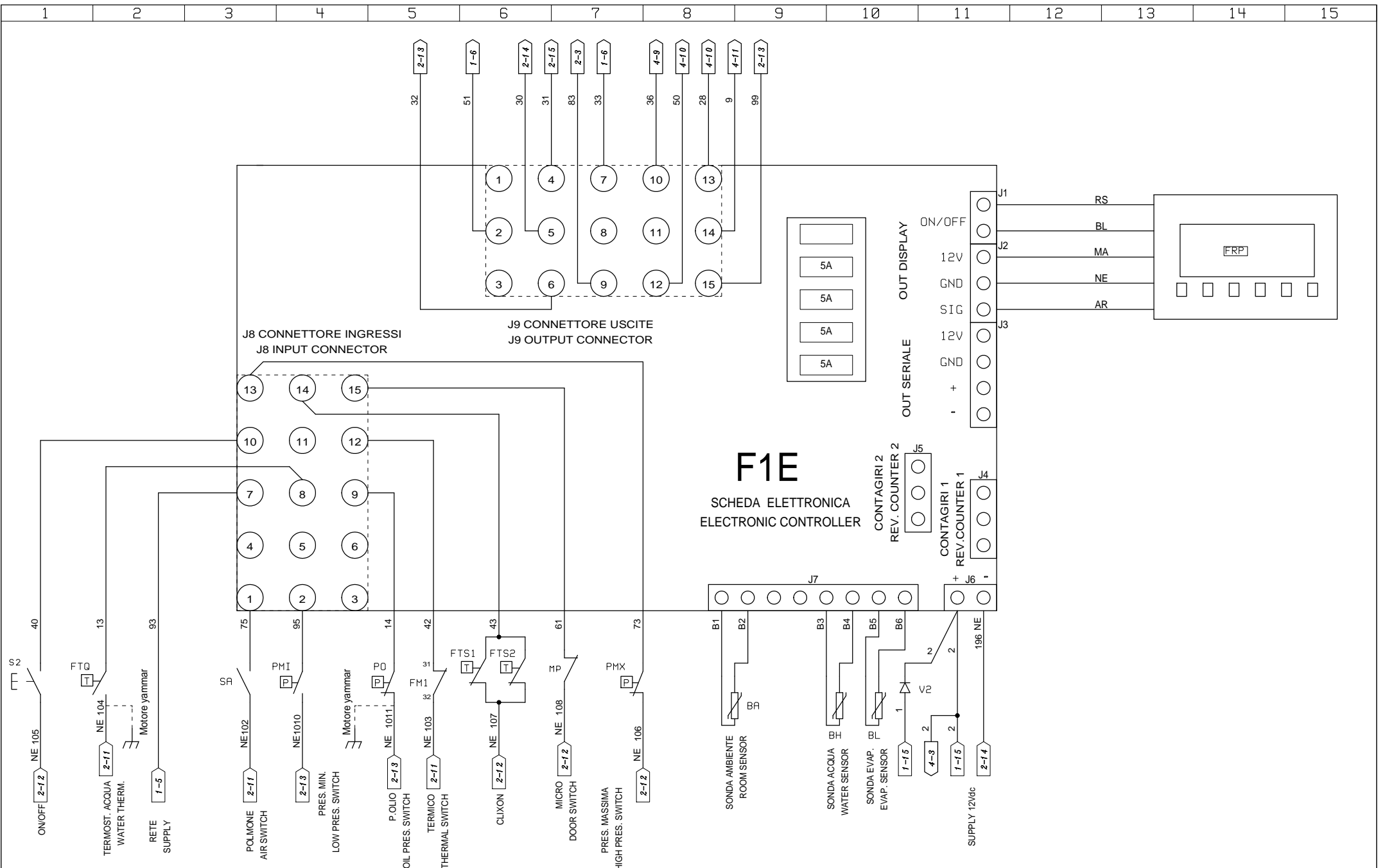

	MODELLO <b>UNO120T...</b>	REV.nr.  	DISEGNO nr. <b>WDB016</b>	FOGLIO nr.: <b>3 DI 5</b>
	DATA:  	Approvato  	Disegnato <b>Soncini</b>	Approvato <b>Soncini</b>

**CIRCUITO D'EMERGENZA (EMERGENCY CIRCUIT)**

- |     |   |  |
|-----|---|--|
| SV  | INTERRUTTORE VENTOLE D'EMERGENZA                | FANS EMERGENCYSWITCH                   |
| SPM | PUSANTE CANDELETTE/START EMERGENZA              | GLOW/PLUGS EMERGENCYSTARTPUSH-BUTTON   |
| SF  | INTERRUTTORE POMPA NAFTA EMERGENZA              | DIESEL FUEL PUMP EMERGENCYSWITCH       |
| EC  | RESISTENZA ECCITAZIONE ALTERNATORE IN EMERGENZA | EMERGENCY EXCITING ALTERNATOR RESISTOR |
| KMP | RELE' AUSILIARIO                                | AUXILIARY RELAY                        |

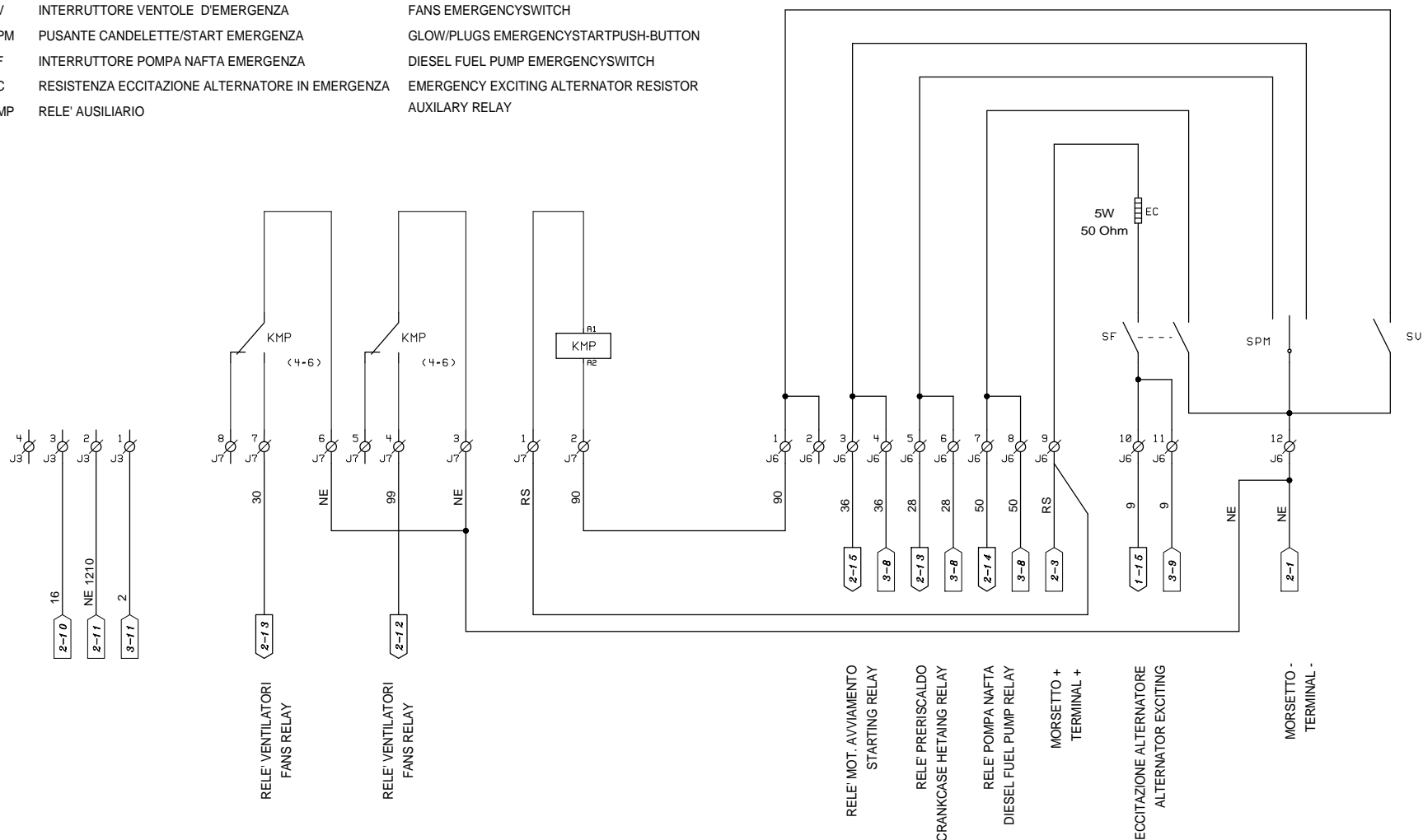

NA	NC
(4-4)	
(4-5)	



MODELLO  
UNO120T...

REV.nr.	02	Corretto errore su MVC
DATA:	06/07/2012	Approvato SONCINI

DISSEGNO nr.	WDB016	FOGLIO nr:	4 DI 5
Disegnato	Soncini	Approvato	Soncini
		DATA:	12-03-2014

LEGENDA SCHEMA ELETTRICO / WIRING DIAGRAM LEGENDA

ALT	ALTERNATORE	ALTERNATOR	FGS	KLIXON COMPRESSORE SCROLL	KLIXON COMPRESSOR SCROLL
BA-BA2	SONDA CELLA	ROOM SENSOR	FIS	FUSIBILI TRASFORMATORE	TRASFORMER FUSES
BH	SONDA RADIATORE	RADIATOR SENSOR	P1MX	PRESSOSTATO VENTOLA CONDENSATORE	HP PRESSURE SWITCH
E1	CANDELETTE	GLOW PLUGS	BL	SONDA USCITA ARIA EVAPORATORE	SUPPLY AIR BY EVAPORATOR SENSOR
FM1	INTERRUTTORE AUTOMATICO	AUTOMATIC SWITCH			
F1E	CENTRALINA ELETTRONICA	ELECTRONIC CONTROL UNIT			
F8-9-10-11-12-13-8/B-9/B-10/B	FUSIBILI VENTOLE EVAPORATORE	EVAPORATORS FANS FUSES			
F3/B	FUS. SOL. FREDDO EVAP. SUPPLEMENTARE	COOLING-CYCLE SOL. FUSE FOR AUXILARY EVAP.			
F4/B	FUS. SOL. CALDO EVAP. SUPPLEMENTARE	HEATING-CYCLE SOL. FUSE FOR AUXILARY EVAP.			
F20	FUSIBILE PROTEZIONE SCHEDA	FUSE CARD PROTECTION			
FA	FILTRO ARIA	AIR FILTER			
F4	FUSIBILE SCHEDA MULTITEMPERATURA	MULTITEMPERATURE BOARD FUSE			
FA2	FUSIBILE FRIZIONE	CLUTCH FUSE			
FA3	FUSIBILE POMPA NAFTA	DIESEL FUEL PUMP FUSE			
FA4	FUSIBILE SOLENOIDE STOP GASOLIO	DIESEL FUEL STOP SOLENOID VALVE FUSE			
FA5	FUSIBILE SOLENOIDE SBRINAMENTO	DEFROST SOLENOID VALVE FUSE			
FA6	FUSIBILE SOLENOIDE ALTA VELOCITA'	HIGH SPEED SOLENOID VSLVE SPEED			
FA7	FUSIBILE BOBINA MOTORINO DI AVVIAMENTO	STARTING MOTOR FUSE			
FA8	FUSIBILE CIRCUITO AUSILIARIO	AUXILARY CIRCUIT FUSE			
FA11	FUSIBILE CANDELETTE	GLOW PLUGS FUSE			
FB	FUSIBILE BATTERIA	FUSE BATTERY			
FTQ	TERMOSTATO TEMPERATURA ACQUA	WATER TEMPERATURE THERMOSTAT			
FTS1-2	CLIXON SBRINAMENTO	DEFROST CLIXON			
M	CONTORE MECCANICO	MECHANICAL HOUR METER			
HI	SUONERIA	BELL			
K1	TELERUTTORE MOTORE ELETTRICO	ELECTRIC MOTOR CONTACTOR			
K2	TELERUTTORE INVERSIONE DI FASE	PHASE REVERSAL CONTACTOR			
K8-9-10 KVE1-2	RELE' VENTOLE EVAPORATORE	EVAPORATOR FAN RELAY			
K94	RELE' AVVIAMENTO	STARTING UP RELAY			
KF1-2	RELE' FREDDO	COOLING-CYCLE RELAY			
KC1-2	RELE' CALDO	HEATING-CYCLE RELAY			
KFP	RELE' POMPA NAFTA	DIESEL FUEL PUMP RELAY			
KFR	RELE' VENTOLE CONDENSATORE SCHEDA	CONDENSER FAN RELAY POWER BOARD			
KP-KP1	RELE' PARZIALIZZAZIONE	OFF-LOADING RELAY			
KPR1	RELE' PRERISCALDO	CRANKCASE HETAING RELAY			
KSF	SEQUENZIATORE DI FASI	PHASE SEQUENCER			
KYAV	RELE' SOLENOIDE ALTA VELOCITA'	HIGH SPEED SOLENOID VALVE RELAY			
KYS	RELE' SOLENOIDE DI SBRINAMENTO	DEFROST SOLENOID VALVE RELAY			
M1	MOTORE ELETTRICO	ELECTRIC MOTOR			
M8-9-10 MVE1-2-3	MOTORE VENTOLE EVAPORATORE	EVAPORATORS FANS MOTORS			
MP	MICROPORTA	DOOR SWITCH			
MTA	MOTORINO D'AVVIAMENTO	STARTING MOTOR			
PMI	PRESSOSTATO DI MINIMA	LOW PRESSURE SWITCH			
PMX	PRESSOSTATO DI MASSIMA	HIGH PRESSURE SWITCH			
PN	POMPA NAFTA	DIESEL FUEL PUMP			
PO	PRESSOSTATO OLIO	OIL PRESSURE SWITCH			
SA	POLMONE	AIR SWITCH			
S2	ON/OFF REMOTO	REMOTE ON/OFF			
YAV	SOLENOIDE ALTA VELOCITA'	HIGH SPEED SOLENOID VALVE			
YN	SOLENOIDE STOP GASOLIO	DIESEL FUEL STOP SOLENOID VALVE			
YS	SOLENOIDE SBRINAMENTO	DEFROST SOLENOID VALVE			
YF1-2	SOLENOIDE FREDDO	COOLING-CYCLE SOLENOID VALVE			
YC1-2	SOLENOIDE CALDO	HEATING-CYCLE SOLENOID VALVE			
YFH	FRIZIONE	CLUTCH			
YP	SOLENOIDE PARZIALIZZAZIONE	OFF-LOADING SOLENOID			
Y3V	SOLENOIDE TRE VIE	THREE WAY SOLENOID			
J	CONNETTORE	CONNECTOR			
TAL	TRASFORMATORE ALIMENTAZIONE	TRANSFORMER			
F5-F6	FUSIBILE VENTOLA CONDENSATORE	CONDENSER FAN FUSE			
M5-M6	VENTOLA CONDENSATORE	CONDENSER FAN			
K5-K6	RELE' VENTOLA CONDENSATORE	CONDENSER FAN RELAY			
KR	RELE' RETE	STAND-BY RELAY			

ALLARMI / ALARMS

A01	GUASTO SONDA AMBIENTE	DAMAGED SENSOR ROOM
A04	ALLARME PRES. MINIMA	LOW PRES. SWITCH ALARM
A05	ALLARME LIVELLO OLIO	OIL LEVEL ALARM
A06	ALLARME FILTRO ARIA	AIR FILTER ALARM
A07	ALLARME TEMP. ACQUA	RADIATOR WATER TEMP. ALARM
A08	MICROPORTA	DOOR SWITCH OPEN ALARM
A09	PORTA APERTA	DOOR OPEN ALARM
A10	ALLARME PRESSIONE OLIO	OIL PRESSURE ALARM
A11	ALLARME PRES. DI MASSIMA	HIGH PRESSURE SWITCH ALARM
A12	ALLARME ALTA TEMPERATURA	HIGH TEMPERATURE ALARM
A13	ALLARME BASSA TEMP.	LOW TEMPERATURE ALARM
A14	PROTEZIONE TERMICA	THERMAL RELAY ALARM
A15	LIVELLO BATTERIA BASSO	LOW BATTERY LEVEL ALARM
A16	MANCATA PARTENZA	STARTING FAILURE
A17	GUASTO ALTERNATORE	DAMAGED ALTERNATOR
A18	GUASTO SONDA ACQUA	DAM. SENSOR RADIATOR WATER



MODELLO  
UN0120T...

REV.nr.	
DATA:	Approvato

DISEGNO nr. <b>WDB016</b>		FOGLIO nr: <b>5</b> DI <b>5</b>
Disegnato Soncini	Approvato Soncini	DATA: 12-03-2014